



SMART HOME

PVC PIPES & FITTING FOR DRAINAGE SOLUTIONS

"SUPERIOR GERMAN QUALITY"



ABOUT

The Egyptian German Industrial Corporate - EGIC was founded in 1991 to market all types of sanitary products and related accessories. Joining Bänninger, our German partners, we introduced PP-R systems to the water supply in the Egyptian market, then expanded our entire production to produce and market all types of reliable plumbing and sanitary products.

EGIC has established top-class manufacturing facilities; including four facilities in Egypt and one in Germany, where we produce water supply and drainage solutions from numerous plastic materials and copper (polypropylene, PVC and polyethylene) under the best-known brands; Bänninger, Kessel, and Smart Home. One of those four factories is the largest copper foundry in the Middle East that manufactures the purest bronze bars, valves, and other related accessories.

By constantly adapting our products to the needs of the market, EGIC eventually became a trendsetter and a leading developer of benchmark quality in polymer and plastic products. We manufacture an economically innovative wide product range of PP-R pipes and fittings for drinkable cold & hot water as well as PP & PVC pipes and fittings for drainage, where we provide complete home solutions for different residential and industrial projects across the world.

Our applied raw material technologies optimize the material characteristics for the protection of the environment. The use of polypropylene raw materials for manufacturing ensures a socially compatible, hygienic and healthy packaging for the most precious commodity: clean drinking water

Our promise is to not only satisfy but to also exceed our customers' expectations by offering them the highest quality products as well as a wide range of support services. Our outstanding customer relations skills ensure efficient delivery, which in return results in customer loyalty.

At EGIC we believe in teamwork, progress, honesty, open communication and a better tomorrow.

*Founded by
Omar Safey El Dine*



EGIC company was established in early **1991** with the intent to market all types of plumbing-related products. Overtime, **EGIC is a pioneer and market leader** in manufacturing pipes and fittings for water supply and drainage, using numerous plastic materials: Polypropylene, PVC and Polyethylene. As a result, the company was positioned as a main sanitary solution supplier in the construction value chain, and was known for its superior, high-quality, German products.

EGIC's Timeline since 1991

- 1991** EGIC was founded as an importer of top-class plumbing products.
- 1995** EGIC was the first company to introduce PPR water supply solutions to the Egyptian Market.
- 1997** EGIC launched its integrated customer service loyalty program. EGIC introduced a new PP push-to-fit drainage solutions.
- 2000** EGIC started its first corporate social responsibility initiative via establishing Nahdet Beni Suef Foundation.
- 2001** EGIC established its first manufacturing facility to locally produce PPR water supply solutions.
- 2006** EGIC expanded to its second manufacturing facility to locally produce UPVC drainage solutions.
- 2013** EGIC implemented the SAP system. EGIC established the Egyptian Plumbers Foundation as part of EGIC's corporate social responsibility program.
- 2014** EGIC launched its PVC cleaning cement & adhesives as well as new pumping systems in order to provide an integrated and complete home solution strategy. EGIC acquired its third manufacturing facility.
- 2016** EGIC established one of the largest bronze and brass foundries in the Middle East.
- 2019** EGIC expanded its manufacturing process to produce the new Kessel shower drains and Smart Home accessories.

EGIC Facilities

- Cairo Head Office.
- Bani Suef Manufacturing Facility.
- Bani Suef Bronze/Brass Foundry.
- October | Manufacturing Facility.
- October II Manufacturing Facility.
- Customer Service Branches Across Egypt.

QUALITY ASSURANCE

Our promise is to be a dependable provider of comprehensive and integrated home solutions of superior German quality, with the support of our exemplary customer care service, comprehensive warranties, and outstanding distribution network.

EGIC's entire production line has been adjusted to fit European standards, which have been previously approved and certified by different accredited independent international institutes.

Those standards are being sustained by our Quality Assurance laboratories which test all raw materials, products and effectiveness.

All products undergo tests in abnormal conditions to guarantee optimum quality, through using the highest quality raw material Borealis, Basell, Sabic and Formosa implying the required standards of the following certifications: DVGW, SKZ, EOS, GL, NOPWASD, IGH and Certificates of quality process ISO 9001, ISO 14001, ISO 45001, ISO 17025.



COMPLETE HOME SOLUTIONS

Home is where most of our time is spent, and investing in high-quality water Plumbing solutions is of the utmost importance, in order to ensure a stable water supply for a peaceful and hassle-free life.



- 1 PP-R Water Supply Solutions
- 2 PPR-R Water Supply Solutions with UV Resistance
- 3 PVC Drainage Solutions
- 4 Floor Drains
- 5 Gully traps
- 6 Inspection Chamber for Outdoor Drainage Solutions
- 7 Backwater Valve for Outdoor Drainage Solutions
- 8 Underground Push to Fit Drainage Solutions
- 9 Lifting Station for Basements
- 10 Water channels for Garage and Swimming Pools

Related Plumbing Solutions: Valves, Flexible Hoses, Lubricant, Adhesives, Waterproof cementitious coating and water pumps.

PRODUCTS

1.1 Indoor/Outdoor Solutions	10
1.2 Floor drains	24
1.3 Outdoor Solutions	30
1.4 Concealed Cistern	44
1.5 Complementary products	46

SYSTEM STRUCTURE

2.1. Scope of Application	52
2.2. Chemical Resistance	54
2.3. System Benefits	62
2.4 . Marking	64
2.5. Raw Material	68
2.6. Structure Design	72
2.7. Important Design Principle	72
2.8. System Advantage	72

Quality Assurance

3.1. System Standards	78
3.2. System Control	79
3.3. Internal Control	79
3.4. Testing and accepting incoming Goods	81
3.5. In-process Inspection	81
3.6. Process Control	81
3.7. Final Inspection	81
3.8. External Control	83
3.9. Quality Management	83

Installation

4.1 Introduction	86
4.2 Procedure	87
4.3 Installing of pipe clamps	88
4.4 Trenchin	90
4.5 Pipe assembly	95

Storage

5.1 Introduction	100
5.2 Procedure	101



"Eco Friendly Connections"

INDEX

Products

1.1 Indoor/Outdoor Solutions	10
1.2 Floor drains	24
1.3 Outdoor Solutions	30
1.4 Concealed Cistern	44
1.5 Complementary products	46

Technical Information

PVC Pipes and Fittings

Smart Home PVC-U sewage piping system is one of the most comprehensive solutions on the market with a full range from 3/4" to 160mm in diameter. Smart Home is a pioneer in the development and marketing of PVC-U systems for this application and is well-known for its excellent product quality, mainly used for non-pressure drainage lines.

The advantages of Smart Home solutions are that they are well accepted, lightweight to prevent damage during handling and installation, resistant to a wide variety of chemicals, nonexplosive, and are not prone to electrolytic corrosion. The fittings are designed with high impact strength, which helps to prevent damage during handling and installation. All parts are assembled easily using solvent cement to accommodate thermal or ground movement.

Pipes and fittings are manufactured according to ES 1717, ISO 4435, DIN 19534, DIN EN 1401, DIN EN 1329, DIN 8061/8062, ISO 3633, ASTM D3311, ASTM D2665, ASTM D2241, IQS 1512, ASTM D1785 and ASTM F441 standards suitable for use underground for general municipal drainage. All products comply with or exceed relevant International standards to ensure reliability and long-lasting service.



*"Eco Friendly Connections"
Zero Leakage, Zero Contamination, Zero Corrosion, Zero Blockage*



Pipes

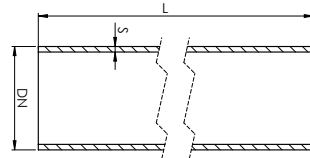

Code	dn	l	s	kg
333060020	3/4	6	2.9	0.250
333060001	32	6	1.8	0.282
333060002	32	6	2.4	0.356
333060007	1	6	1.8	0.283
333060008	1	6	2.4	0.366
333010001	48	6	2.5	0.571
333010002	48	6	3.7	0.801
333070004	50	5.9	1.8	0.460
333070005	50	5.9	2.5	0.647
333070006	50	5.9	3.7	0.844
333020001	60	6	2.7	0.789
333020002	60	6	3.9	1.085
333020010	63	6	1.9	0.608
333020011	63	6	3	0.918
333030002	75	6	3	1.082
333030003	75	6	4	1.396
333030004	75	6	5	1.755
333030005	90	6	3	1.343
333040001	110	6	2.8	1.541
333040002	110	6	3	1.606
333040003	110	6	4	2.093
333040004	110	6	5	2.563
333050001	160	6	4	3.105
333050002	160	6	5	3.908

Code	dn	l	s	kg/m
333140107	90	5.5	3	1.234
333140108	90	5.5	2	0.868
333140105	110	5.5	3	1.603
333140104	110	5.5	4	2.064
333140103	110	5.5	5	2.521
333140111	110	6	4	2.064
333140112	110	6	5	2.521
333140102	160	5.5	3	2.284
333140101	160	5.5	4	3.019
333140113	160	6	4	3.019
333140115	160	5.9	4	3.019
333140116	160	5.9	5	3.750
333140114	160	6	5	3.750
333140109	160	5.5	7	5.163

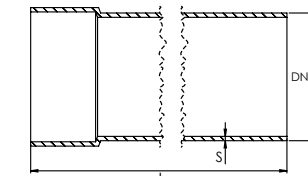

Multi Layer PiPeS with solvent cement socket



Multi-layer Pipes

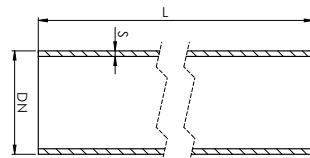

Code	dn	l	s	kg
333140011	75	5.9	2.3	0.841
333140012	75	5.9	3	1.056
333140021	75	6	3	1.056
333140013	75	5.9	4	1.387
333140014	75	6	4	1.0387
333140005	110	5.9	3	1.609
333140004	110	6	3	1.609
333140002	110	5.9	4	2.064
333140001	110	6	4	2.064
333140003	110	5.9	5	2.521
333140015	110	6	5	2.521
333140019	110	5.9	6	2.997
333140007	160	5.9	4	3.019
333140017	160	6	4	3.019
333140006	160	5.9	5	3.750
333140018	160	6	5	3.750
333140020	160	5.9	6	4.483
333140016	160	6	6	4.483
333140022	200	5.9	4	3.790

Code	dn	l	s	kg/m
333140110	160	6	3	2.260
333140106	200	5.9	4	3.790

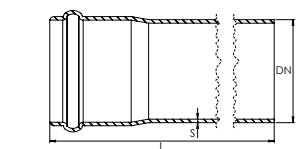

Multi Layer PiPeS with ring socket

We produce pipes with socketed end cement socket and rubber ring socket upon request from 32 mm -250 mm

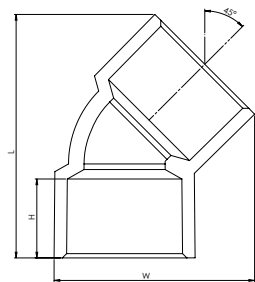

Elbow 45°

Code	dn	L	W	H	kg
353020010	3/4"	56.5	46.5	18.4	0.020
353010000	32	66.4	55	22.2	0.032
353010007	1"	66.5	55	22.2	0.039
353010001	48	91.7	77.2	30.5	0.075
353010006	50	91.5	77.2	30.5	0.065
353010002	60	107.4	91.5	34.5	0.095
353010008	63	108	95	32	0.117
353010003	75	126	113	40.3	0.179
353010009	90	145	129	42	0.234
353010004	110	163	155	43.8	0.402
353010005	160	260.6	220.5	68.2	0.938

Code	dn	L	W	H	kg
353020016	48	91	91	32	0.105
353020017	50	91	91	32	0.094
353020015	60	109	109	36	0.16
353020008	63	104.2	104.2	31	0.144
353020014	75	125	125	40	0.220
353020009	90	141	141	42	0.311
353020013	110	172	172	51	0.537

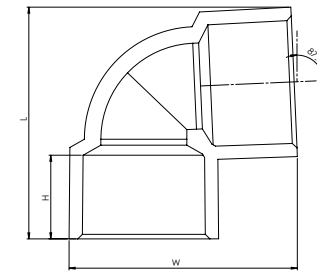

Short Elbow 87.5°

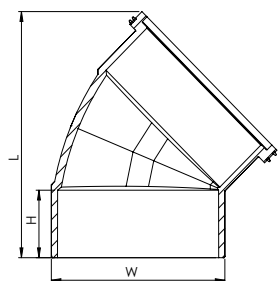

Elbow 45° with expansion Joint

Code	dn	L	H	S	kg
353010013	110	100	45	4.3	0.465

Code	dn	L	W	H	kg
353030001	60	136.2	136.2	35	0.231
353030002	75	156.7	156.7	40.5	0.350
353030003	110	210	210	45.2	0.806
353030004	160	285.3	285.3	70	1.624

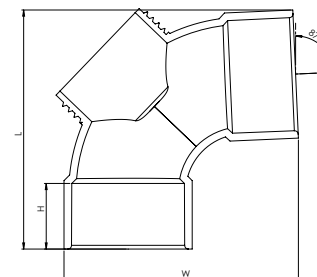

Elbow 87.5° with Access Door

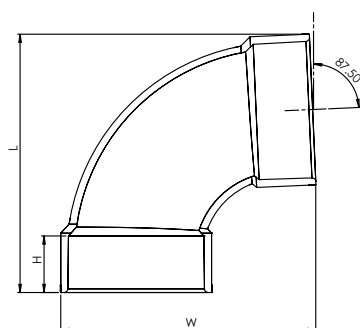

Elbow 87.5°

Code	dn	L	W	H	kg
353020010	3/4"	51	51	18	0.023
353020000	32	65.6	65.6	22.4	0.040
353020007	1"	65.7	65.7	22.5	0.050
353020001	48	102	102	30	0.109
353020006	50	102	102	30	0.103
353020002	60	125.3	125.3	40	0.17
353020003	75	150.5	150.5	40	0.288
353020004	110	203	203	46	0.695
353020005	160	300	300	70	1.481

Code	dn	L	W	H	Door	kg
353030007	110	190	190	48	110	0.824

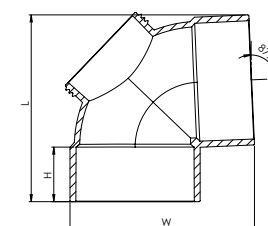

Short Elbow 87.5° with Access Door

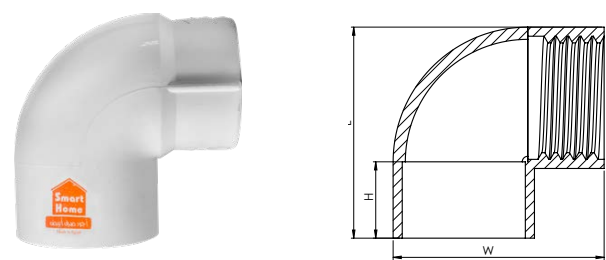

Elbow 87.5° with inner thread

Code	dn	Thread	L	W	H	kg
353040002	48*1.5"	1.5"	86.5	86	30	0.111
353040004	50*1.5"	1.5"	86.5	86	30	0.104

Code	dn	L	W	H	kg
353060010	3/4"	65.5	48.1	18.7	0.032
353060000	32	95	75	22	0.070
353060007	1"	95	75	22.1	0.08
353060001	48	127	97	30	0.161
353060002	50	140	103	32	0.140
353060003	60	153	117	35	0.226
353060004	75	189	140	40	0.365
353060005	110	244	200	45.5	0.930
353060006	160	346.8	285	70	1.891

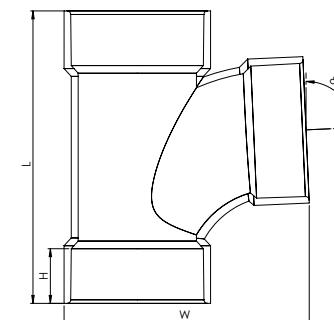

Tee 87.5°

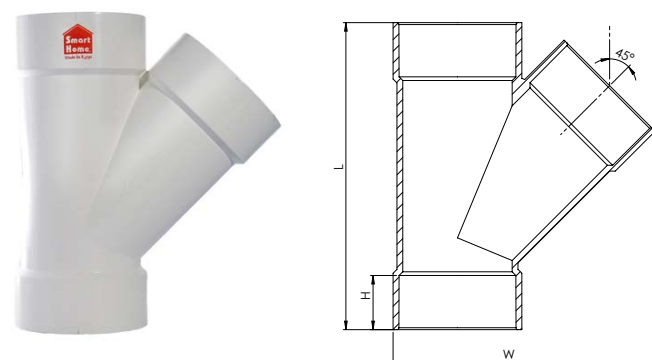

Tee 45°

Code	dn	L	W	H	kg
353050010	3/4"	84	64	18.4	0.042
353050012	32	95.8	79	22.4	0.073
353050007	1"	95	80	22.5	0.081
353050001	48	142	114	30	0.165
353050006	50	142	114	30	0.154
353050002	60	166.8	138	34.2	0.278
353050008	63	177.3	146.5	32.3	0.273
353050003	75	203.3	170.3	40	0.420
353050009	90	238	202.3	42	0.599
353050004	110	282.3	245.3	46.3	1.08
353050005	160	397	345.5	70	2.618

Code	dn	L	W	H	kg
353080001	75/60	166.6	136.3	40	0.309
353080005	110/50	199.2	166.5	46	0.690
353080002	110/60	198.8	166.5	46	0.635
353080003	110/75	199.9	188	45	0.686
353080004	160/110	289	252	70	1.424

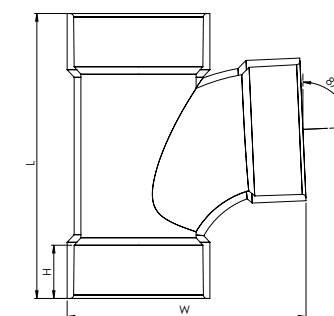

Tee 87.5° Reducer

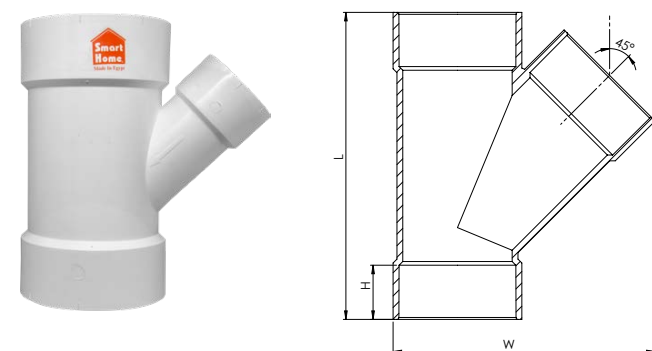

Tee 45° Reducer

Code	dn	L	W	H	kg
353070003	110/50	239.7	190	46	0.695
353070001	110/60	223	201	46	0.755
353070002	110/75	260.2	215	46	0.915
353070005	160/110	328	308	71	1.962

Code	dn	L	W	H	kg
353060008	63	139	103	32	0.201
353060009	90	187.5	141	42.5	0.431
353080011	110	216	170	48	0.760

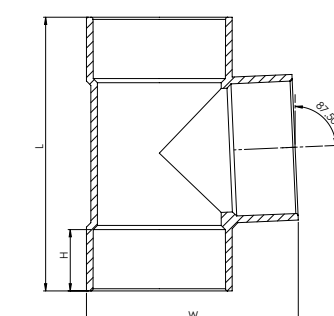

Short Tee 87.5°

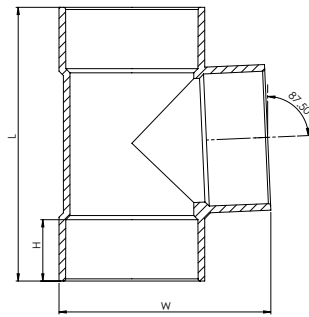

Short Tee 87.5° Reducer

Code	dn	L	W	H	kg
353080017	110/48	216	160	48	0.675
353080016	110/50	216	160	48	0.670
353080015	110/60	216	168	48	0.695
353080014	110/63	216	168	48	0.690
353080013	110/75	216	168.5	48	0.690
353080012	110/90	216	169.5	48	0.710

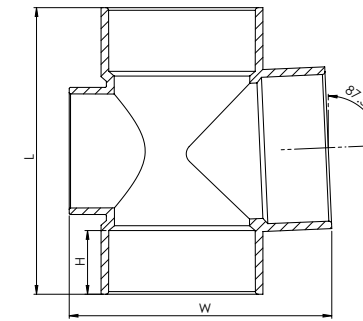

Short Tee 87.5° with Access Door

Code	dn	L	W	H	Door	kg
353092101	110/48	216	180	48	75	720
353092105	110/50	216	180	48	75	715
353092102	110/60	216	188	48	75	745
353092103	110/75	216	189	48	75	755
353092104	110/110	216	190	48	110	0.925

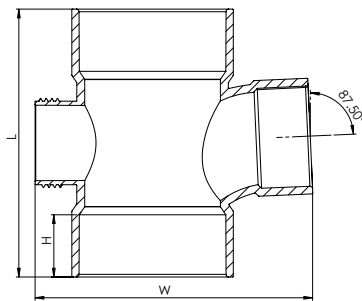

Tee 87.5° with Access Door

Code	dn	L	W	H	Door	kg
353090001	60	145	150	36	75	0.301
353090002	75	189	170	40	75	0.441
353090003	110	242	240	45	110	1.060
353090004	160	345	310	70	110	2.000

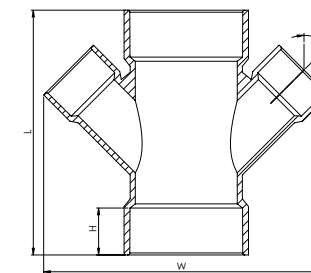

Cross 45°

Code	dn	L	W	H	kg
353091022	110/50	240	265	46.4	0.755
353091021	110/60	240	278.8	46.4	0.817
353091020	110/75	240	311.7	46.4	0.908
353094001	110/110	280	367.8	51.3	1.600

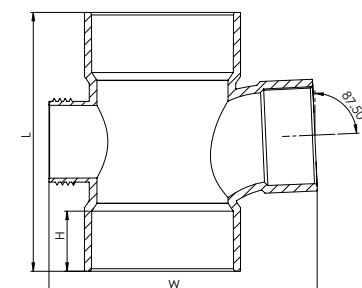

Tee 87.5° Reducer with Access Door Reducer

Code	dn	L	W	H	Door	kg
353092001	75/60	166	166.2	40	75	0.374
353092002	110/60	198	210	45.7	75	0.709
353092003	110/75	201	220	47	110	0.739
353092004	160/110	287	291	70	110	1.536

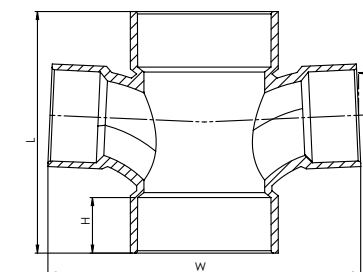

Cross 87.5°

Code	dn	L	W	H	kg
353091003	75/75	189	207	45	0.499
353091001	110/110	245	293	45	1.365

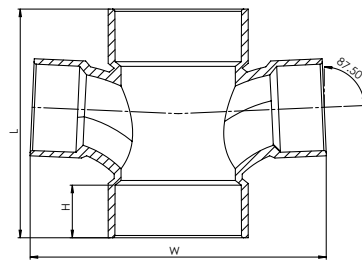

Cross 87.5° Reducer

Code	dn	L	W	H	kg
353091012	110/50	200	214	46	0.720
353091011	110/60	200	214.5	46	0.730
353091010	110/75	200	255	46	0.875

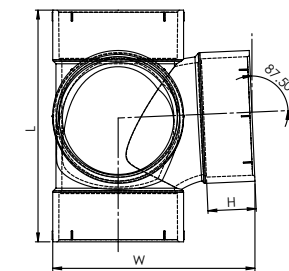

Side Cross

Code	dn	L	W	H	kg
353091004	110	216	188	46	0.928

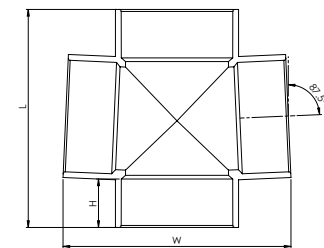

Short Cross 87.5°

Code	dn	L	W	H	kg
353091015	60	139	142	35	0.254
353091016	63	139	142	36	0.195
353091013	90	187	190	42	0.500
353091030	110	216	220	48	0.877
353091002	160	305	316	68.3	1.806

Code	dn	L	H	kg
353093010	3/4"	39	18	0.015
353093000	32	48	22	0.027
353093007	1"	48	22	0.029
353093001	48	65	31	0.058
353093006	50	65	31	0.047
353093002	60	80	37	0.093
353093008	63	66	31	0.081
353093003	75	94	44	0.155
353093009	90	87	42	0.166
353093004	110	109	52	0.322
353093005	160	146	70	0.653

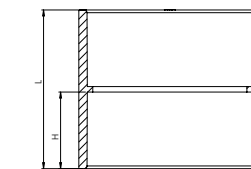

Socket

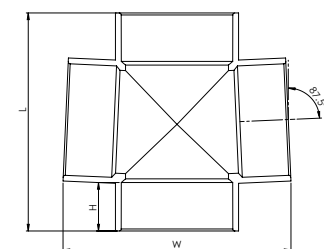

Short Cross 87.5° Reducer

Code	dn	L	W	H	kg
353091014	90/63	187	189	42	0.414
353091036	110/48	216	208	48	0.695
353091035	110/50	216	207	48	0.690
353091034	110/60	216	225	48	0.730
353091033	110/63	216	225	48	0.735
353091032	110/75	216	225	48	0.760
353091031	110/90	216	226	48	0.703

Code	dn	L	kg
373099916	110	109	0.300
373099915	160	146	0.640

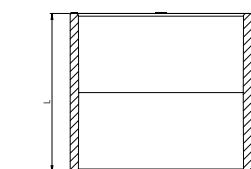

Repairing Socket

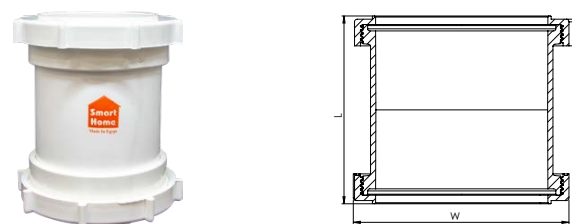

Repairing Socket with Expansion Joint

Code	dn	L	W	kg
373099913	75	121.5	114.5	0.331
373099914	110	141	155.4	0.679
373099917	160	180.1	514.5	1.179

Code	dn	L	H	kg
353095012	48	28	24	0.026
353095011	50	28.5	25	0.03
353095014	60	29	25	0.035
353095016	63	35	30	0.040
353095017	75	69	65	0.050
353095015	110	100	40	0.140
353095018	160	43	38	0.230

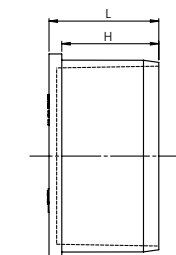

Floor Drain Plug

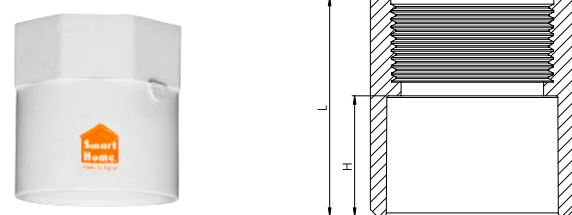

Socket with Inner Thread

Code	dn	Thread	L	H	kg
353096301	48*1.5"	48*1.5"	60.4	30	0.077

Code	dn	L	H1	H2	kg
373050015	32/3/4"	25.5	22	22.4	0.010
373050016	1"/3/4"	25.5	22	22.4	0.012
373050008	48/32	38.1	30	27.6	0.040
373050011	48/1"	38	29	31.4	0.037
373050007	50/48	32.8	29	28	0.011
373050001	60/48	45.1	36	30.7	0.061
373050002	75/48	51.5	43.3	35.2	0.124
373050009	75/50	51.7	42.8	36	0.116
373050003	75/60	51.4	43	36.6	0.109
373050014	75/3"	66	54.8	55.3	0.166
373050010	110/50	60.7	50	36	0.239
373050004	110/60	65.7	54.6	41.5	0.265
373050005	110/75	66.6	55.5	50	0.268
373099905	114/110	40	36	34	0.060
373050006	160/110	76.5	66	55.6	0.568

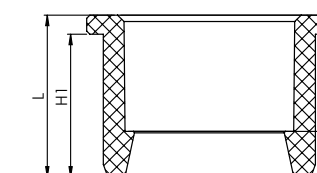

Reducing Bush

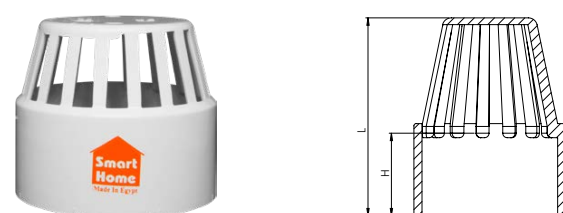

Air Vent

Code	dn	L	H	kg
373040003	60	87	38	0.061
373040002	75	102	46	0.091
373040001	110	102	52	0.150

Code	dn	L	H1	H2	Z	kg
373050020	90/50	118	43	30	49	0.158
373050021	90/60	117	42.7	33	39	0.166
373050022	90/63	117	42.7	33	35	0.170
373050023	90/75	117	43.5	38.6	28	0.184
373050013	90/3"	100.6	38.8	39	9	0.114
373050029	110/48	132.6	52	29.6	70	0.204
373050024	110/50	132.3	54	35.6	63	0.238
373050025	110/60	131.1	54	39	54	0.243
373050026	110/63	131.7	53	38.5	50.8	0.249
373050027	110/75	132	52	40	41.1	0.263
373050028	110/90	132	53.3	47	25.7	0.281
373050030	160/110	173.6	74	46	60	0.506

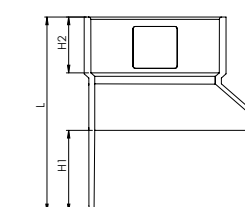

Eccentric Reducer

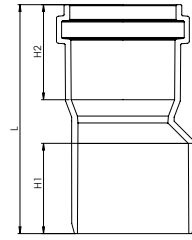

Eccentric Reducer with Gasket

Code	dn	L	H1	H2	Z	kg
373050032	60/50	112.4	45.3	45	13	0.090
373050031	63/50	115.5	45.3	45	15	0.097

Code	dn	L	H	Door	kg
353095001	60	78.3	43	75	0.121
353095005	63	65	40	75	0.113
353095002	75	83	47	75	0.149
353095006	90	82	43	75	0.166
353095003	110	92.5	47.4	110	0.322
353095004	160	132	75.5	110	0.575

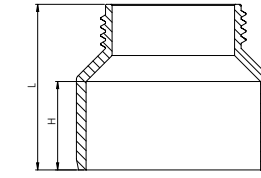

Cleaning Insert with Access Door



Pipe Plug

Code	dn	L	H	kg
353095026	3/4"	23	20	0.010
353095019	32	24.6	20	0.0110
353095020	1"	24.6	20	0.012
353095024	48	28.6	22.7	0.021
353095021	50	30	25.2	0.022
353095025	60	36	28	0.039
353095022	75	43	35	0.053
353095010	110	56	43	0.190
353095023	160	62	50.3	0.200

Code	dn	L	W	H	kg
353099900	50	98	163	30.7	0.157
353099902	75	150	230	40	0.462
353099901	110	210	305	45	1.218
353099929	114/110	210	310	48	1.138

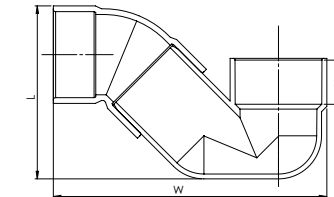

Siphon

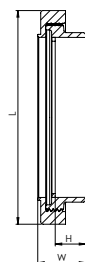

Expansion Joint

Code	dn	L	H	W	kg
373099908	75	30.6	16.7	114.5	0.097
373099909	110	34.6	20	155	0.184
373099910	160	38	22	180	0.323

Code	Pipe size	Thickness	Width	Hex head bolt	Fisher Bolt	fisher
Measurements in mm						
353096506	32	2	20	M6*20	8*90	S10
353096505	50	2	20	M6*20	8*90	S10
353096501	60	2	20	M6*20	8*90	S10
353096502	75	2.5	30	M6*20	10*120	S12
353096503	110	3	30	M6*20	10*120	S12
353096504	160	2.5	30	M6*20	10*120	S12



PVC Pipes Clamps

Technical Information

Smart Home floor drains are designed with superior German quality to receive and convey wastewater to the main sewerage. These drains are made of PVC to tolerate heavy loads and excellent resistance to aggressive wastewater. All floor drains include three inlets and one outlet that are pre-opened for easy and less time installation.

Smart Design for preventing unpleasant odors by using new easily installed trap elbow sealed with O-ring before outlet, and easily removable for cleaning purposes.

Smart Home floor drains fit modern and elegant bathrooms, floors, kitchens, or roof areas where standing water is expected.

"Eco Friendly Connections"

Zero Leakage, Zero Contamination, Zero Corrosion, Zero Blockage

FLOOR DRAINS



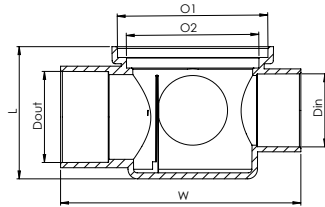

Code	dn		L	W	O1	O2	kg
	outlet	inlet					
373010033	60	3x48	110	191	125	110	0.616
373010032	60	3x60	110	195	125	110	0.630
373010034	75	3x48	110	196	125	110	0.647
373010031	75	3x60	110	200	125	110	0.680
373010041	90	3x63	120	211	125	110	0.731
373010018	60	3x50	110	195	125	110	0.600
373010035	75	3x50	110	195	125	110	0.645

Floor Drain 110/125 with Odor Trap

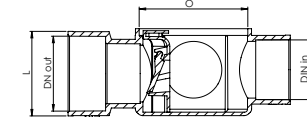

Drain 8.8 cm

Code	dn	L	W	O	kg
373010029	75/60	88	224	110	0.585

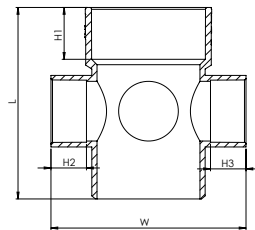

Code	dn	L	W	H1	H2	H3	kg
373010019	110/63/50	193	200	51	35	35	0.775
373010023	110/48/48	193	200	51	35	35	0.718
373010010	110/60/60	193	190	51	35	40	0.695
373010040	110/75/50	193	190	51	35	40	0.670
373010039	110/75/75	193	190	51	35	40	0.808

Drainage Collector

Code	dn	L	W	O	kg
373010022	60/48	70	210	110	0.461
373010013	63/50	70	210	110	0.435

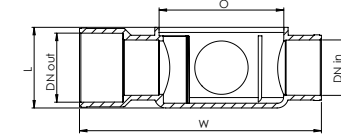

Drain 7 cm

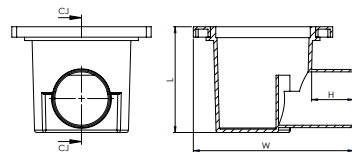

Code	dn	L	W	H1	kg
373099901	48	77	145	35	0.240

Small Drain

Code	dn	L	H	W	kg
373020002	110	97.6	12.6	14.8	0.253
373020003	125	97.6	14	20	0.390

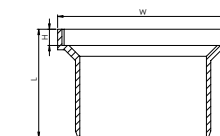

Drain upper section made of PVC



Closed Cover



Open Cover

Floor Drain Cover

Code	dn	L	W	kg
373030004	Open 20*20mm	192	192	0.255
373030003	Closed 20*20mm	192	192	0.260

Code	Outlet	dn Inlet	L	W	O1	kg
373010011	60(75)	3x50(60)	110	225	125	0.680
373010012	60(75)	3x48(60)	110	225	125	0.695

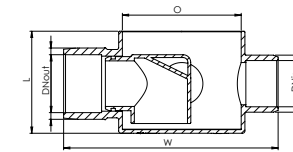

Drain 125 with odor trap



Rain Drain with Cover

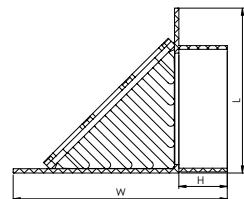

Code	dn	L	W	H	kg
373099906	75	152	194	42	0.633
373099907	110	152	194	45	0.526



Inspection Point Drain without odor trap
160 - 200 - 250

Code	Outlet	dn Inlet	L	W	O1	kg
373010015	110	3x110	155	240	160	1.185
373010020	110	3x110	190	280	200	1.185
373010043	160	3*160	250	360	250	2.700

Technical Information

Outdoor Drainage Solutions

Smart Home outdoor solutions are designed to protect homes and properties from drainage conditions. They are made from polypropylene to efficiently move any volume of wastewater to the main sewage system. Utilizing the most durable materials, our Smart Home system is manufactured with Superior German Quality to guarantee high durability, low maintenance, and a long life span.

Smart Home outdoor solutions include water channels, gully traps, backwater valves, and inspection chambers for ease of installation with PVC pipes or polypropylene connections.

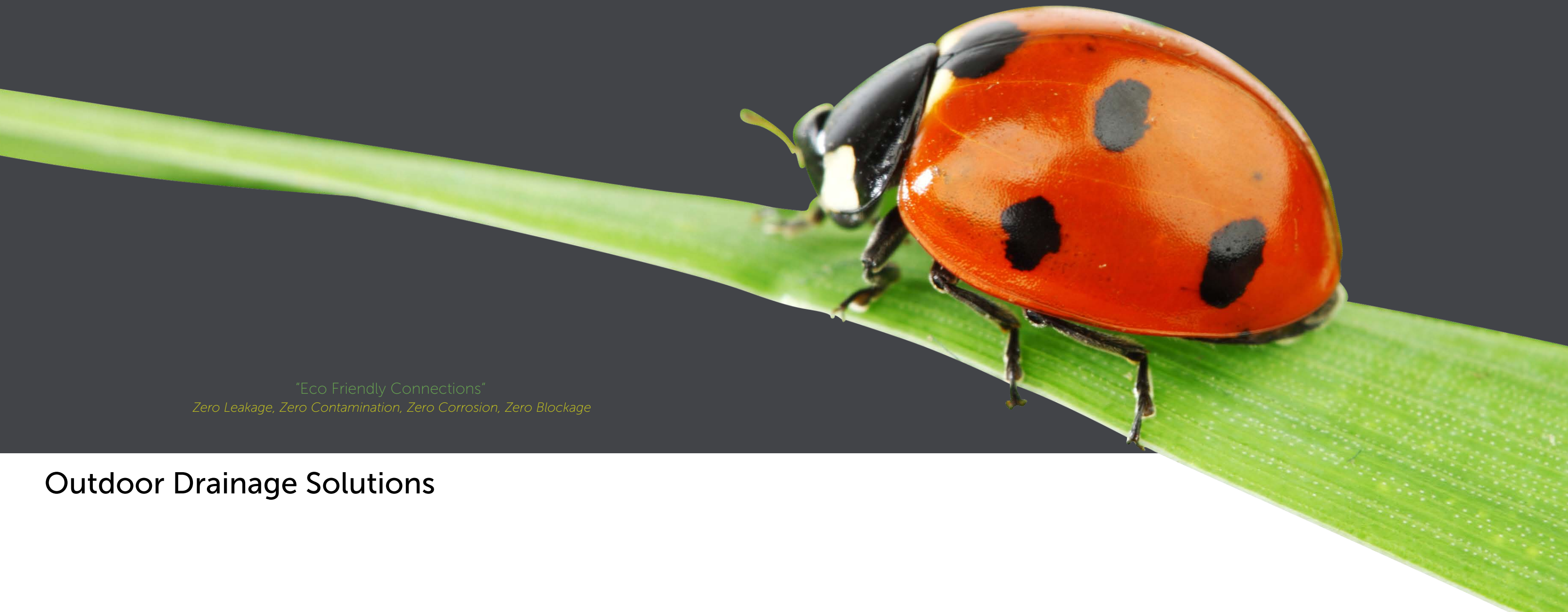

*"Eco Friendly Connections"
Zero Leakage, Zero Contamination, Zero Corrosion, Zero Blockage*

Outdoor Drainage Solutions

Outdoor Drainage Solutions

Gully Trap with Lateral 3 inlets Ø75 and 1 outlet Ø110

353096101 Gully trap with slotted plastic cover (250*250mm)

353096102 Gully trap with closed plastic cover (250*250mm)



General Specifications

Materials: upper and lower sections are made of Polypropylene
Accept wastewater from kitchens, water sinks, bathtubs and washing machines to the main sewage system

With vertically adjustable upper section (18 mm)

Available with Integral odour trap, sludge basket and triple inlet plugs

Flow rate: 1.8 liters/sec.

Load Class: 300 kg

Advantages

Rotatable Lower section to the drainage system

Adjustable upper section up to 18 mm.

Available with vertical extension.

Removeable cover to ease the access for cleaning and maintenance.

Outdoor Drainage Solutions

Gully Trap with Lateral 1 inlet Ø110 and 1 outlet Ø110

353096103 Gully trap with slotted plastic cover (250*250mm)

353096104 Gully trap with closed plastic cover (250*250mm)



General Specifications

Material: lower section made of PVC and the upper section is made of Polypropylene
Accept wastewater from kitchens, water sinks, bathtubs and washing machines to the main sewage system

With vertically adjustable upper section (18 mm)

Available with Integral odour trap, sludge basket and triple inlet plugs

Flow rate: 1.8 litres/sec.

Load Class: 300 kg

Advantages

Rotatable Lower section to the drainage system

Adjustable upper section up to 18 mm.

Available with vertical extension.

Removeable cover to ease the access for cleaning and maintenance.



Outdoor Drainage Solutions

Inspection Chamber Ø600*600 mm

353099914 Inspection chamber 600*600mm with cover

353099915 Vertical Extension

353099916 Optional Vertical Extension

353099918 Cover + Frame

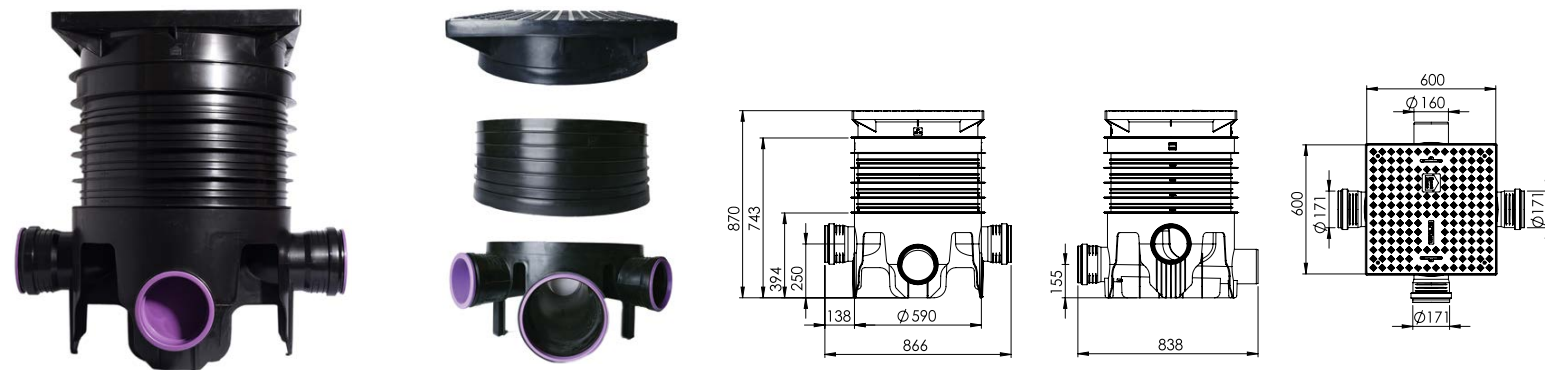

Inspection chamber Body

Material: Made of Polypropylene

Internal diameter: 548mm

Adjustable Height: 870mm including the vertical extension

Base Inlets: 3 socket-pipe inlets Ø160mm

Outlet: 1 pipe outlet Ø160mm

Vertical Extension: 410mm height with 5 steps to allow height extending or trimming by 69mm (cutting lines are marked by CUT HERE)

Optional Vertical Extension: 285mm height with 2 extra Ø110mm inlets PP socket-pipes installed at any desired depth above the main body

Flow rate: 2500 liters/min.

Cover

Material: Made of Polypropylene

Size: 600*600mm

Load Class: withstand up to 2 Tons of static load (A15)

Locking: four fixing screws to hold the cover plate securely in place

Handles: two loose handles made of stainless steel for ease installation and maintenance

Advantages

Excellent resistance for aggressive wastewater

Easy and quick to install with rubber o-ring seals

Significant reduction in maintenance and handling costs

High durability and zero leakage

Allow on-site height adjustment



Inspection Chamber 500*500 mm

- 353099903** Inspection chamber 500*500mm with cover
- 353099908** Vertical Extension
- 353099911** Cover 500*500mm + Frame
- 353099909** Cover 500*500 + Lower Base
- 353099910** Lower Base

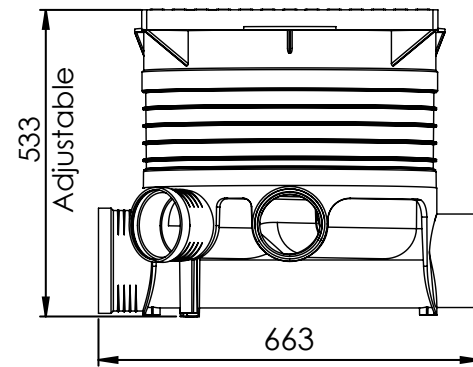

Inspection chamber Body	Cover	Advantages
Material: Made of Polypropylene	Material: Made of Polypropylene	Composed of 3 pieces assembled as males and females
Internal diameter:	Size: 500*500mm	Silicon is preferred for assembling for a tight close
Adjustable Height: 530mm including the vertical extension	Load Class: withstand up to 1.5 Tons of static load (A15)	Excellent resistance for aggressive wastewater
Base Inlets: 4 inlets Ø110mm and 1 inlets Ø160mm		Easy and quick to install
Outlet: 1 pipe outlet Ø160mm		Significant reduction in maintenance and handling costs
Vertical Extension: 200mm		High durability and zero leakage
Flow rate: 300 liters/min.		Allow on-site height adjustment

Drainage Water Channel 100*100 mm

- 353096201** Water Channel 100*100mm with Polypropylene Cover
- 353096210** Water Channel 100*100mm with Stainless steel (304) Cover
- 353096401** Quad Branch/Tee/Elbow
- 353096212** Vertical outlet 75mm
- 353096205** Vertical outlet 110mm
- 353096203** End caps for both ends of the channel + Adapter for pipe joint

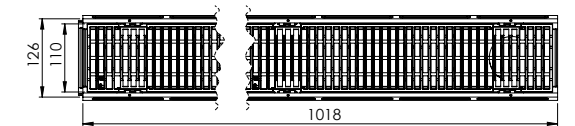

General Specifications	Advantages	Installation instructions
Material: made of polypropylene	The self-locking covers with shearing protection	1. Pour in the concrete bed and press in the channel with covers fitted. Ensuring that the channel is level and set between 3 and 5 mm.
Length: 1 meter	Tongue and groove connection for a professional installation	2. Below the finished surface, continue to pour concrete until it covers the horizontal side strip. Lay the first course of the surface over this concrete.
Width and Depth: 100*100mm	Newly designed PP self-locking mesh grating	3. Fill joints with sand as required.
Lateral Outlets: two optional side outlets Ø 110 mm or Ø 75mm.	Increased water intake due to mesh width 8 x 21mm. (= 511 cm2/m.)	
Vertical Outlet: one optional vertical outlet Ø 110mm or Ø 75mm.		
Flow rate: 150 liters/min.		
Accessory Pack: End caps for both ends of the channel (no.3) Adapter for pipe joint DN 75/100 including bolts (no.4) Quad Branch/Tee/Elbow (no.5) Vertical outlet 75mm or 110mm (no.6)		
Cover types: Polypropylene Cover Withstand up to A15 Stainless steel Cover o The cover is made of Stainless steel 304 o The thickness is 1.5mm o The weight is 1.3 Kg o It can withstand up to 500 Kg		

Outdoor Drainage Solutions

Drainage Water Channel 200*200 mm

353096211 Water Channel 200*200mm

353096204 End caps for both ends of the channel + Adapter for pipe joint

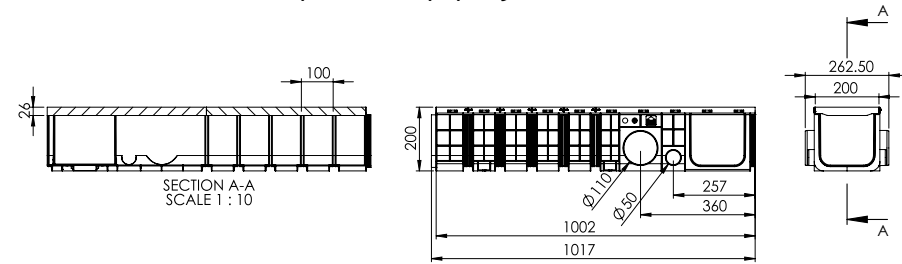

Advantages

Material: made of polypropylene

Length: 1 meter

Width and Depth: 200*200mm

Lateral Outlets: Four optional side outlets (Ø 110 mm at each side & Ø 50mm at each side)

Vertical Outlet: One optional vertical outlet (Ø 110mm or Ø 75mm).

Flow rate: 500 liters/min.

Load Class: withstand up to 1.5 Tons of static load (A15)

Cover: 2 polypropylene covers (500mm each)

Designed for easy attachment at both ends for extending purposes either in longitudinal or transversal directions.

Every unit contains 5 optional cutting steps that allow length trimming by 10cm for each step (cutting lines are marked by CUT HERE)

Designed to be anchored to set the location before the final fixation



BACKWATER VALVES

353099940 Backwater Valve 110mm

353099941 Backwater Valve 160mm

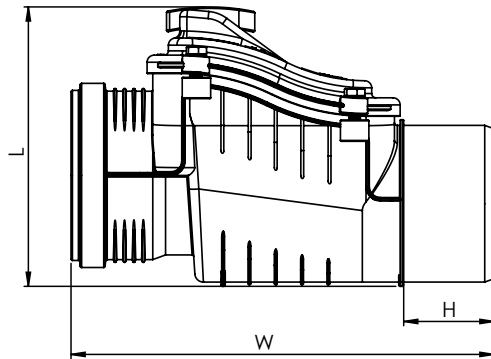

Smart Home Backwater valves (non-return valves) secure residential units on lower floors and basements against backflow of sewage into piping systems that result from blockage of main lines or flooding caused by rainwater. The use of Backwater valves is mandatory to face these emergency conditions, according to international building standards.

Smart Home Backwater valves are equipped with an automatic closing system that starts to operate when flood-water appears and close in the event of inverse water flow.

General Specifications

Sizes: 110 mm and 160 mm

Inlet and outlet: Push-fit socketed inlet and outlet

Materials

The Body and cover is made of ABS

Contains four rubber gaskets to prevent unpleasant odors or leakage through the inlet, the gate, the cover, and the handle.

The flap (gate) includes a stainless steel plate for sustainability, anti-rust and to prevent rodents from coming up the drain pipe.

Operation

Allows wastewater to flow in only one direction

Includes emergency lock for closure

Ensures excellent chemical resistance to various components of sewage.

It has an access cover for easy periodic maintenance or access to remove any trapped material.

Easy to install and maintain.

High temperature resistant up to 95° degrees.



Drainage Lifting Station

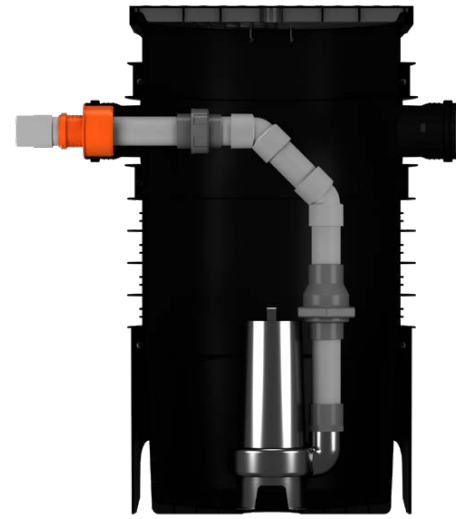

Smart Home lifting station used for drainage and rainwater lifting from the basements and garages, where the drainage level is below the level of the public infrastructure lines. The use of drainage lifting unit pumps is mandatory to face these emergency conditions, according to international building standards.

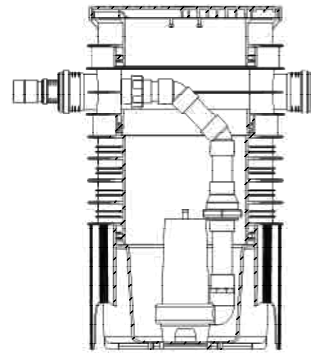

Specifications of Smart Home Lifting Station

- Equipped with a submersible, 1 horsepower
- Maximum flow rate to lift wastewater 500 liters/min. at a depth of 2.8 meters
- The pump is equipped with a sharp blade made of stainless steel 304, that works on cutting paper waste
- The pump body made of cast iron and stainless steel 304
- Include backwater valve
- The pump can be removed for ease of service

The Chamber Body:

- Internal diameter: Ø548mm
- Material: Manufactured from the purest materials of polypropylene to ensure highest flexibility
- Height: adjustable height with vertical extension that contains 5 steps to allow height extending
- Extensions are assembled to each other's and sealed by O-ring made of rubber

Main features:

- Self-cleaning, which prevents the deposition of impurities in it
- Easy to assemble and install due to special seal plugs
- High-temperature resistance
- Excellent Chemical-resistance to all sewage fluids.

Cover:

- Size:** 60 cm x 60 cm
- Material:** Made of polypropylene – PP.
- Load Class:** Load class (A15) (tested under 1.5Tons load)
- Attached with 4 fixing screws to secure it into place
- Easy access for cleaning and maintenance

Inlets:

One socket-pipe inlet Ø110mm with O-ring seal made of natural rubber suitable for drainage applications.

Outlets:

One Ø60mm PVC outlet



Complementary Products

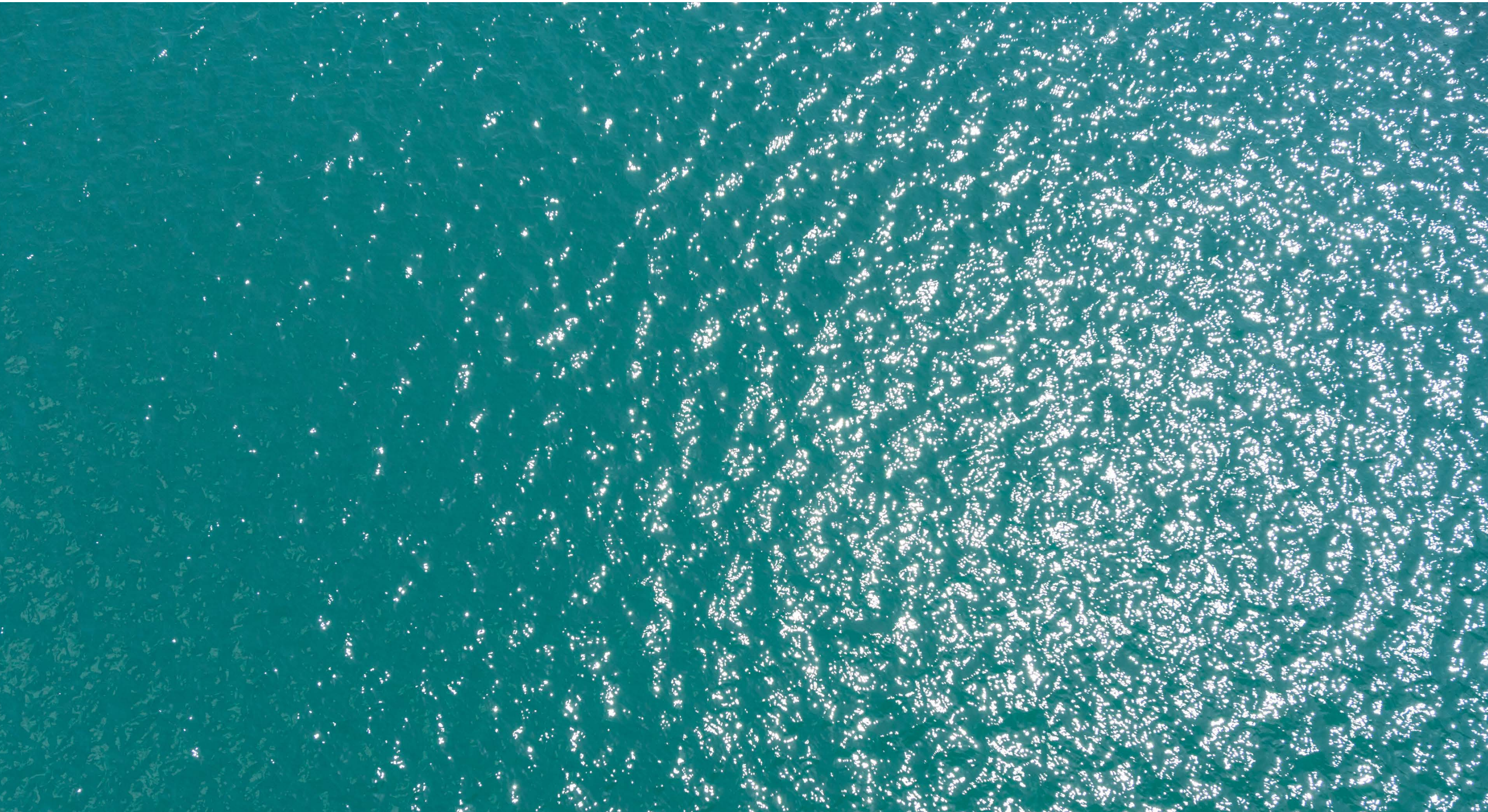

Complementary Products

Dual Flush Mechanical Concealed Cistern

353096201 Water Channel 100*100mm with Polypropylene Cover

353096210 Water Channel 100*100mm with Stainless steel (304) Cover

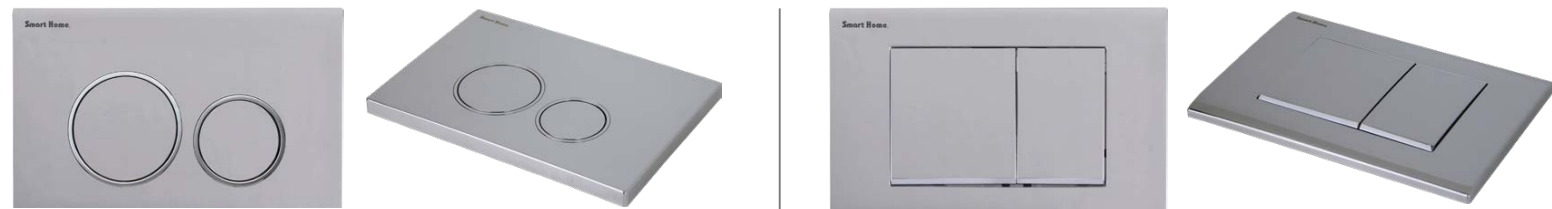
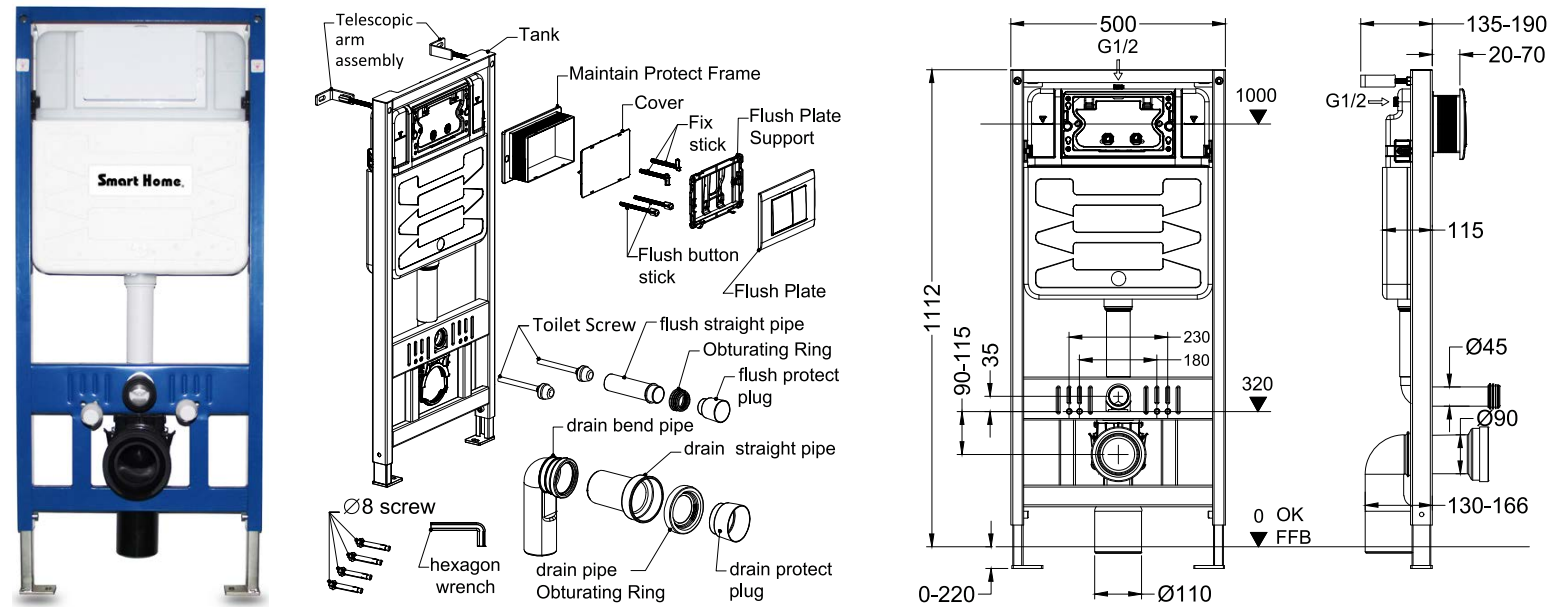

Smart Home Concealed cisterns are installed in front of solid walls or gypsum board, to a point that only the flushing button is visible or accessible. The concealed cistern is used for wall-hung toilets in modern bathrooms to give luxuries homogeneous style

The Frame:

The frame length is 111mm that withstand up to 400 kg
The frame includes galvanized iron arms to be installed in the wall with a fisher (with adjustable length from 13.5cm to 19cm)
The frame includes galvanized iron legs to be installed in the ground by a Metric Anchors with adjustable length up to 22cm
Steel frame coated with a thin layer to prevent the metal from rusting and the bad weather conditions

Flush Plates

Flush plates are available in different shapes and colors to suit different designs
A protective cover is available to protect the plates during the finishing work
The plate extension can be shortened according to the depth of the tank from the wall

Accessories

Includes Dual-flush Valve for water-saving (5/7.5 liters or 4/6 liters or 3/5.4 liters)
Includes a premium angle valve $\frac{1}{2}$ "x $\frac{3}{8}$ " to fill in the water tank automatically
Includes 1 adjustable elbow (90mm) made of polyethylene and an optional reducer made of PVC (90/10mm) for the toilet wastewater
Includes adjustable pipe (Ø45mm – 18 cm) for the flushing system.
Includes plugs to project the sewerage line, to be removed after finishing the walls.

Advantages

The plastic tank is surrounded by foam to prevent water condensation
Water supply connectors can be installed from the side of the top of the water tank



Pipe Lubricant

Code	Kg	Pieces / Box
377020020	150 ml Tube	50
377020021	250 ml	50
377020022	500 ml	24



A pipe jointing compound based on vegetable soap lubricants applicable for all drinkable water pipes and drainage solutions to permit easy and speedy fixing of sealing joints on nearly all pipe materials.

Bitumen Emulsion (BITUCOAT)

ASTM D-1227

Code	Kg
385010005	3
385010006	12



BITUCOAT is waterproofing based on emulsion bitumen. It is designed to be used on walls and floors to prevent water ingress and dampness from the ground. It will provide a waterproof membrane on concrete and brick foundations, retaining walls and bridge abutments. It protects concrete structures against attack by sulphates present in soils.

Cementitious Waterproof Coating

- 385010008** Cementitious Waterproof Coating - Powder
- 385010009** Cementitious Waterproof Coating - Liquid



Smart Home Cementitious Waterproof Coating is a two-component, acrylic copolymer -modified liquid and cementitious powder that requires on-site mixing or combining to form the ideal product to provide a durable waterproof coating to concrete.

Smart Home Cementitious Waterproof Coating is suitable for indoor and outdoor surfaces before tiling it with ceramic or marble or any finishing material needed.

Smart Home Cementitious Waterproof Coating is designed for application by brush, roll or spry with a minimum of 2 crossway coats

Typical Applications

- As a waterproof coating for water-retaining floors like bathrooms, kitchens, pools and wet areas
- As excellent waterproof for positive water pressure
- To protect concrete surfaces from carbonation and chloride attack

Advantages

- High resistance to positive water pressure
- Provides a perfect waterproof layer without any joints
- Excellent adhesion – bonds to porous and non-porous surfaces
- Limited flexibility, fit into small spaces and corners
- Breathable, allowing the substrate to breathe
- Easy for handling
- Smart Home Cementitious Waterproof Coating can be applied to 24 hour-old concrete, thereby giving immediate protection and curing.

Packing

SH Cementitious Waterproof Coating is available in 20kg (15kg powder + 5kg liquid)

PVC Solvent Cement:



correspond ASTM D-2564
The best solvent cement solution for Grey UPVC pressure pipes

- 377060006**
125 gm
- 377060007**
250 gm
- 377060008**
500 gm



correspond ASTM F493
The best solvent cement solution for UPVC and CPVC pipes (Hot)

- 377090006**
125 gm
- 377090007**
250 gm
- 377090008**
500 gm



correspond ASTM D-2564
The best solvent cement solution for UPVC pipes (Cold)

- 377080006**
125 gm
- 377080007**
250 gm
- 377080008**
500 gm



correspond ASTM D-2846 and ASTM F-493
The best Cleaner for all pipes (UPVC , ABS and CPVC)

- 377070003**
125 gm
- 377070002**
250 gm



"Eco Friendly Connections"

INDEX

SYSTEM STRUCTURES

2.1. Scope of Application	52
2.2. Chemical Resistance	54
2.3. System Benefits	62
2.4. Marking	64
2.5. Raw Material	68
2.6. Structure Design	72
2.7. Important Design Principle	72
2.8. System Advantage	72

2.1 Scope of Application

Smart Home pipes and fittings are mainly used for Non- pressure drainage lines resistant to low and high temperature water for domestic and industrial.

- In single and multiple family house constructions
- In apartment construction
- In renovation construction
- In industrial plants
- In large-scale kitchens and laundries
- In schools, universities
- In hotels, convalescent homes
- In infirmaries and many others

Inside these buildings, the Smart Home system can be used for:

- Individual and collective lines
- Downpipes
- Ventilation pipes
- Interior rainwater pipes
- Pipes for central dust extraction systems
- Pipes, fittings and sealing elements are also suitable for the transportation of chemically aggressive
- Electric and telecommunication cables ducts
- Air conditioning drainage system





2.2 Chemical Resistance

INTRODUCTION

The five tables in this document summarize the data provided in a number of unplasticized polyvinyl chloride chemical resistance tables at present in use in various studies, derived from both practical experience and test results.

Table I contains an evaluation of the chemical resistance to a number of fluids judged to be either aggressive or not towards unplasticized polyvinyl chloride. This evaluation is based on values obtained by immersion of unplasticized polyvinyl chloride test specimens in the fluid concentrated at 20 °C and 60 °C and atmospheric pressure, followed in certain cases by the determination of tensile characteristics. Table 2, 3, 4 and 5 list these fluids as to whether or not unplasticized polyvinyl chloride pipe is suitable for use in contact with them at the stated temperature of tensile characteristics.

A subsequent classification will be established with respect to a restricted number of fluids deemed to be technically or commercially more important, using equipment which permits testing under pressure and the determination of the "coefficient or chemical resistance" for each fluid. These tests will thus furnish more complete indication on the use of unplasticized polyvinyl chloride pipes for the transport of stated fluids, including their use under pressure.

1- SCOPE AND FIELD OF APPLICATION

This document establishes a provisional classification of the chemical resistance of unplasticized polyvinyl chloride with respect to about 160 fluids. It is intended to provide general guidelines on the possible utilization of unplasticized polyvinyl chloride piping for the conveyance of fluids.

- At temperature up to 20 °C and 60 °C,
- In the absence of internal and external mechanical stress (for example, flexural stresses due to thrust, rolling loads).

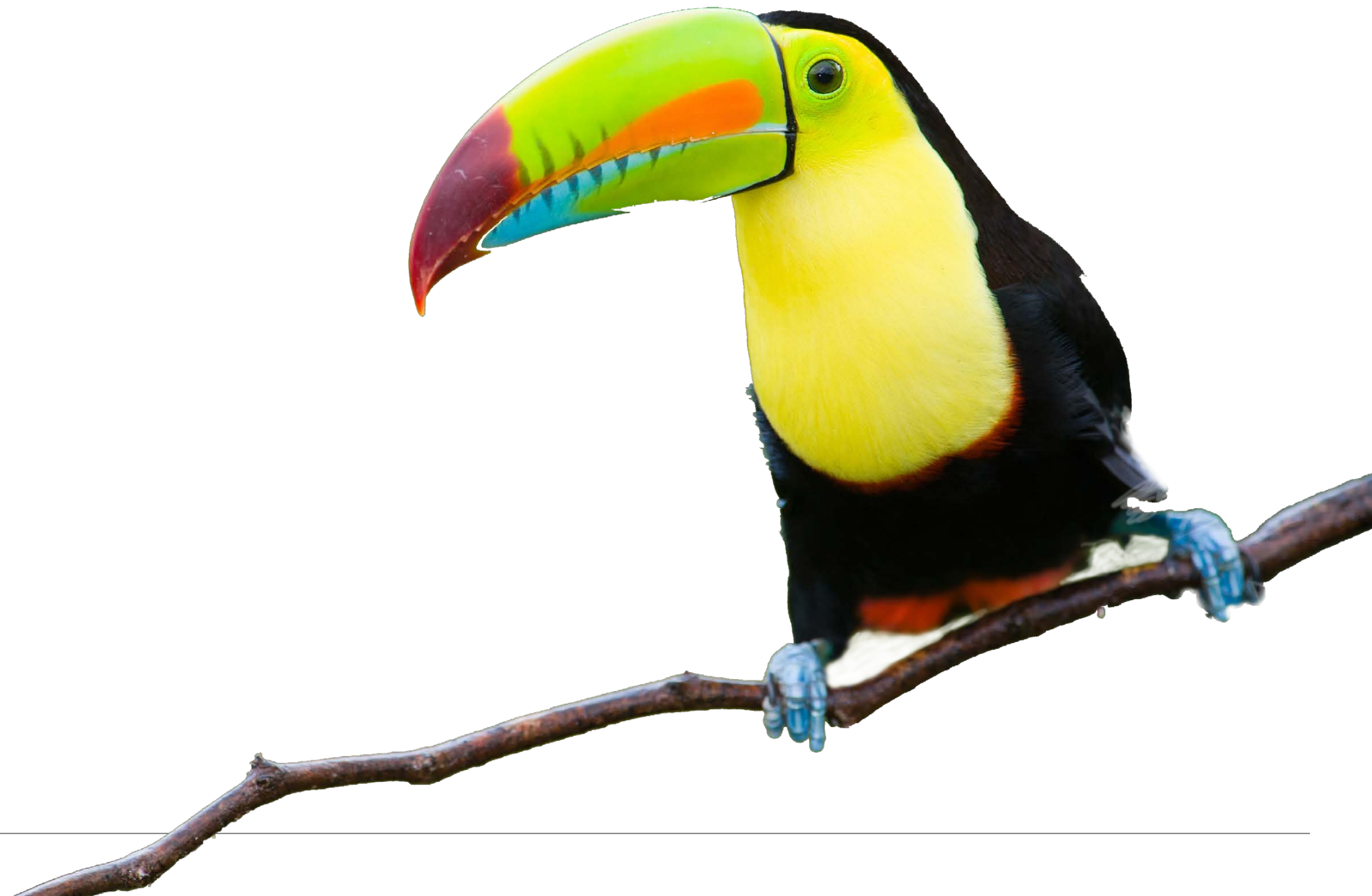

ISO/ TR 7473-1981 (E)

2- DEFINITIONS, SYMBOLS, AND ABBREVIATIONS

The criteria of classification, definitions, symbols, and abbreviations adopted in this document are as follows:

S = Satisfactory

The chemical resistance of unpasteurized polyvinyl chloride exposed to the action of a fluid is classified as "satisfactory" when the results of tests are acknowledged to be "satisfactory" by the majority of the countries participating in the evaluation.

L = Limited

The chemical resistance of unpasteurized polyvinyl chloride exposed to the action of a fluid is classified as "limited" when the results of tests are acknowledged to be "limited" by the majority of the countries participating in the evaluation.

Also classified as "limited" is the resistance to the action of chemical fluids for which judgments "S" and "NS" or "S" and "L" are pronounced to an equal extent.

NS = Not Satisfactory

The chemical resistance of unpasteurized polyvinyl chloride exposed to the action of a fluid is classified as "not satisfactory" when the results of tests are acknowledged to be "not satisfactory" by the majority of the countries participating in the evaluation.

Also classified as "not satisfactory" is the resistance to the action of chemical fluids for which judgments "L" and "NS" are pronounced to an equal extent.

Sat. sol. = Saturated aqueous solution, prepared at 20 °C.

Sol. = Aqueous solution at a concentration higher than 10%, but not saturated.

Dil. sol. = Dilute aqueous solution, at a concentration equal to or lower than 10 %.

Work. sol. = Aqueous solution having the usual concentration for industrial use.

Solution concentrations reported in the text are expressed as a percentage by mass.

The aqueous solutions of sparingly soluble chemicals are considered, as far as chemical action towards unpasteurized polyvinyl chloride is concerned, as saturated solutions.

In table 1, the resistance properties (S, L, NS) are reported on the right side of each fluid, but the same properties are to be in general in this document, common chemical names are used.

For the definition of unpasteurized polyvinyl chloride, see ISO 472, Plastics-Vocabulary.

The symbol for polyvinyl chloride, PVC, given in ISO 1043, Plastics - Symbols, is used in the table headings.

Keys	No.
+ = resistant	Details = Not tested
O = practically resistant	Any = Any concentration
O = partially resistant	Conc. = Concentration Solution
O = not very resistant	Low = Low concentration
... = not resistant	Serv. = Service concentration
	Stand. = Standard, customary
	Disc. = Discolored
	Aq. = Aqueous solution
	Sat. = Cold saturated
	b.p. = Boling point

ISO/ TR 7473 -1981 (E)

TABLE 1 - Chemical resistance of plasticized PVC, not prone to mechanical stress, to various fluids at 20 °C and 60 °C.

Chemical or product	Conc. %	20°c	60°c
Acetaldehyde	40%	NS	-
Acetaldehyde	100%	NS	-
Acetic acid	Glacial	NS	NS
Acetic acid	25%	s	L
Acetic acid	60%	s	L
Acetic anhydride	100%	NS	NS
Acetone	100%	NS	NS
Adipic acid	Sat. sol.	s	L
Allyl alcohol	96%	L	NS
Aluminum chloride	Sat. sol.	s	S
Aluminum potassium sulphate	Sat. sol.	s	S
Aluminum sulphate	Sat. sol.	s	S
Ammonia, dry gas	100%	s	S
Ammonia, liquid	100%	L	NS
Ammonia, aqueous	Oil. sol.	s	L
Ammonium chloride	Sat. sol.	s	S
Ammonium fluoride	20%	s	L
Ammonium nitrate	Sat. sol.	s	S
Ammonium sulphate	Sat. sol.	s	S
Amyl acetate [1 -Pentanol acetate]	100%	NS	NS
Amyl alcohol [1 -Pentanol]	100%	s	L
Aniline	100%	NS	NS
Aniline	Sat. sol.	NS	NS
Aniline hydrochloride	Sat. sol.	NS	NS
Antimony { 111 } chloride	90%	s	S
Anthraquinone sulphonic acid	sol.	s	L
Arsenic acid	Oil. sol.	s	-
Arsenic acid	Sat. sol.	s	L
Beer	-	s	S
Benzaldehyde	0.10%	NS	NS
Benzene	100%	NS	NS
Benzoic acid	Sat. sol.	L	NS
Borax	Sat. sol.	s	L
Boric acid	Oil. sol.	s	L
Bromic acid	10%	s	-

ISO / TR 7 4 73- 1 981 (E)

TABLE 2 - Chemical resistance of unplasticized PVC, not prone to mechanical stress, to various fluids at 20 °C and 60 °C.

Chemical or product	Cone.%	20°C	60°C
Bromine, liquid	100%	NS	NS
Butadiene	100%	s	s
Butane, gas	100%	s	
Butanols	Up to 100 %	s	L
Butyl acetate	100%	NS	NS
Butyl phenol	100%	NS	NS
Butyric acid	20%	s	L
Butyric acid	98%	NS	NS
Calcium chloride	Sat. sol.	s	s
Calcium nitrate	so x	s	s
Carbon dioxide [aqueous solution]	Sat. sol.	s	L
Carbon dioxide, dry gas	100%	s	s
Carbon dioxide, wet gas		s	s
Carbon disulphide	100%	NS	NS
Carbon tetrachloride	100%	NS	NS
Chlorine, dry gas	100%	L	NS
Chlorine, aqueous	Sat. sol.	L	NS
Chloroacetic acid	Sol.	s	L
Chlorosulphonic acid	100%	L	NS
Chromic acid	From 1% to so s	s	L
Citric acid	Sat. sol.	s	s
Copper [11 J chloride	Sat. sol.	s	s
Copper [11] fluoride	2%	s	s
Copper [11 J sulphate	Sat. sol.	s	s
Cresols	Sat. sol.		NS
Cresylic acid [mthyl bonzoic acid]	Sat. sol.		NS
Crotonaldehyde	100%	NS	NS
Cyclohexanol	100%	NS	NS
Cyclohexanone	100%	NS	NS
Developers [photographic]	Work, sol.	s	s
Dextrin	Sat. sol	s	L
Dichloroethane	100%	NS	NS
Dichloromethane	100%	NS	NS
Diethyl ether	100%	NS	
Diglycolic acid	18%	s	L

ISO/ TR 7473-1981 (E)

TABLE 3 - Chemical resistance of unplasticized PVC, not prone to mechanical stress, to various fluids at 20 °C and 60 °C.

Chemical or product	Cone.%	20°C	60°C
Dimethylamine	30%	S	
Ethanediol [Ethylene-glycol]	Work, SOL.	S	s
Ethanol	95%	S	L
Ethyl acetate	100%	NS	NS
Ethyl acrylate	100%	NS	NS
Fluosilicic acid	32%	S	s
Formaldehyde	dil. SOL.	S	L
Formaldehyde	40%	S	s
Formic acid	From 1% to 50%	S	L
Furfuryl alcohol	100%	NS	NS
Gasoline [Aliphatic hydrocarbons]		S	s
Glucose	Sat. sol.	S	L
Glycerol	100%	S	s
Glycolic acid	30%	S	s
Hexadecanol	100%	S	s
Hydrobromic acid	10%	S	L
Hydrobromic acid	50%	S	L
Hydrochloric acid	20%	S	L
Hydrochloric acid	Reather than 30 %	s	s
Hydrofluoric acid	40%	L	NS
Hydrofluoric acid	60%	L	NS
Hydrofluoric acid, gas	100 %	L	NS
Hydrogen	100 %	S	s
Hydrogen peroxide	30%	S	s
Hydrogen sulphide, gas	100%	S	s
Iron { 111 } chloride	Sat. sol.	S	s
Lactic acid	10%	S	L
Lactic acid	From 10% to	L	NS
Lead acetate	90%	S	s
Lead acetate	Oil, sol.	S	s
Lead tetraethyl	Sat, sol.	S	
Magnesium chloride	100%	S	s
Magnesium sulphate	Sat, sol.	S	s
Maleic acid	Sat, sol.	S	L
Methanol	Sat, sol.100%	S	L

ISO/ TR 7473-1981 (E)

TABLE 4 - Chemical resistance of unplasticized PVC, not prone to mechanical stress, to various fluids at 20 °C and 60 °C.

Chemical or product	Cone.%	20°C	60°C
Methyl methacrylate	100%	NS	NS
Milk		s	s
Molasses	Work, sol	s	
Nickel sulphate	Sat. sol	s	L
Nicotinic acid	Work, sol.	s	NS
Nitric acid	Up to 45 %	s	NS
Nitric acid	From so s to 98 %	NS	L
Oils and fats		s	NS
Oleic acid	100 %	s	s
Oleum	10 % of SO3	NS	s
Orthophos phosphoric acid, aqueous	30%	s	L
Orthophos phosphoric acid, aqueous	Greater than 30 %	s	s
Oxalic acid	Oil, sol.	s	s
Oxalic acid	Sat, sol.	s	NS
Oxygen	100 %	s	NS
Ozone	100%	s	NS
Perchloric acid	10 %	s	NS
Perchloric acid	70%	L	L
Petrol [Aliphatic hydrocarbons/benzene]	so l 20	NS	NS
Phenol	90%	NS	L
Phenylhydrazine	100 %	NS	s
Phenylhydrazine hydrochloride	97%	NS	s
Phosphine	100 %	s	s
Phosphorus { 111} chloride	100 %	NS	s
Picric acid	Sat, sol.	s	NS
Potassium bromide	Sat, sol.	s	NS
Potassium chloride	Sat, sol.	s	NS
Potassium chromate	40%	s	NS
Potassium cyanide	sol.	s	NS
Potassium dichromate	40%	s	s
Potassium hexacyanoferrate [I I]	Sat, sol.	s	L
Potassium hexacyanoferrate [I I]	Sat, sol.	s	NS
Potassium hydroxide	sol.	s	NS
Potassium nitrate	Sat, sol.	s	
Potassium permanganate	20%	s	-.

ISO/ TR 7473-1981 (E)

TABLE 5 - Chemical resistance of unplasticized PVC, not prone to mechanical stress to various fluids at 20 °C and 60 °C.

Chemical or product	Cone.%	20°C	60°C
Potassium persulphate	Sat. sol.	s	L
Propane, liquefied gas	100%	s	-
Pyridine	Up to 100 %	NS	-
Seawater	-	s	L
Silver nitrate	Sat. sol.	s	L
Soap	sol.	s	L
Sodium benzoate	35%	s	L
Sodium chlorate	Sat. sol.	s	s
Sodium chloride	Sat. sol.	s	s
Sodium hexacyanoferrate [11]	Sat. sol.	s	s
Sodium hexacyanoferrate [11]	Sat. sol.	s	s
Sodium hydrogen sulphite	Sat. sol.	s	s
Sodium hydroxide	sol.	s	s
Sodium hypochlorite (13%of chlorine)	100%	s	L
Sodium sulphite	Sat. sol.	s	L
Sugar { aqueous solution}	Sat. sol.	s	s
Sulphur dioxide, dry	100%	s	s
Sulphur dioxide, liquid	100%	L	NS
Sulphuric acid	From 40% to 90%	s	L
Sulphuric acid	96%	L	NS
Sulphurous acid	sol.	s	s
Tannic acid	sol.	s	s
Tartaric acid	sol.	s	s
Tin [11] chloride	Sat. sol.	s	s
Toluene	100%	NS	NS
Trichloroethylene	100%	NS	NS
Trimethylol propane	Up to 10 %	s	L
Urea	10 %	s	L
Urine	-	s	L
Vinegar	Up to 80% g/1 of acetic acid	s	s
Vinyl acetate	100%	NS	NS
Wine	-	s	s
Xylol	100%	NS	NS
Yeast	sol.	s	L
Zinc chloride	Sat, sol.	s	s

2.3. System Benefits

Dimensions and performance meet the requirements of Egypt, Germany, America and International standards.

Low Friction Loss

The smooth interior surfaces of Smart Home system assure low friction loss and high flow rate. Additionally, since PVC-U resist rusting, pitting, scaling and corrosion, the high flow rate can be maintained for the life of the piping system.

Easy Installation

Smart Home system is lightweight (approximately one-half the weight of aluminum and one-sixth the weight of steel) reducing transportation, handling, and installation cost. No special tools are required for cutting. These materials can be installed using the solvent cement joining technique.

Cost-effective

Longer pipe lengths, flexibility and the use of narrow trench widths significantly reduce installation costs, the major portion of the total in-site costs.

Non-Flammability

Smart Home system does not support combustion.

Non-conductivity

Smart Home system is a non-conductor of electricity and is therefore not prone to galvanic or electrolytic action.

Effect on elevated temperatures

Smart Home system is capable of handling typical wastewater discharge temperatures up to approximately 60°C and is therefore satisfactory for use in soil and waste systems where continuous full bore discharges of effluent are unlikely to exceed this figure.

Effect of low temperature

The impact strength of Smart Home pipe and fittings decreases with reduction in temperature, therefore, increased care should be exercised if installations are carried in low-temperature conditions.

Corrosion resistant

The inert nature of Smart Home PVC-U pipe provides complete corrosion resistance, and renders wrapping, coating and lining unnecessary. This inert nature ensures that PVC-U sewer and drainage pipes have a long operational life.

Leakage elimination

Groundwater infiltration due to broken and cracked elements in the system, joint opening and ground movement are eliminated by the precision joints, flexible pipe barrel and sealed access points provided by the PVC-U sewer pipe and fittings system. Longer pipe lengths mean fewer joints, further reducing possible sources of leaks, which research has shown to be directly proportional to the number of joints.

The solvent cement joint provided with the system eliminates the contamination of the groundwater and surface water by sewer effluent which causes health hazards, visual pollution and public concern.

Low Thermal Conductivity

Smart Home pipes have a much lower thermal conductivity factor than metal pipe. Therefore, fluids being piped maintain a more constant temperature. In many cases, pipe insulation is not required.

Expansion and contraction

Piping which is being laid in hot weather will be in an expanded condition and will subsequently contract on cooling. It must be remembered that every 6m length of PVC-U pipe will expand or contract approximately 5mm for every 10°C rise or fall in temperature. Precautions against damage due to contraction can be taken by using **SMART HOME** expansion joints.

Beneficial to Public Health

Smart Home system is clean and safe, it is so safe that it is used for intravenous medical tubing, and it is the pipe of choice for ecologically sensitive environments like saltwater aquariums

Best Choice for the Environment

Smart Home system is one of the world's most sustainable products. It is the ideal product for long-term use in underground infrastructure. It requires less energy and fewer resources to manufacture than old-technology materials and its production creates virtually no waste. Moreover, it is produced with sustainable and abundant resources: chlorine, which is derived from salt, and domestically produced natural gas, which helps to reduce the consumption of imported oil.

Clean and Safe Manufacturing

PVC-U pipe manufacturing is extremely efficient, with virtually 100 % of the PVC compound being used. It takes four times less energy to be made than concrete pipe, and half that used for the iron pipe.

Non Toxicity

PVC products are completely non-toxic in normal use and are suitable for use with food. It is a safe material and a socially valuable resource that has been used for more than half a century. It meets all international standards for safety and health for both the products and applications for which it is used.

SYSTEM STRUCTURES

2.4. Marking

Marking of Pipe

1. The Brand
2. Material Type (PVC-U)
3. The Number of Standards specification ex: - ES 1717.
4. Drain, Waste and Vent (DWV) system.
5. The dimension of the pipe (OD*Thickness).
6. The Extrusion Line and Shift No.
7. The Date and Time of production
8. Made in Egypt with superior Germany quality by Egyptian German Industrial Corporate S.A.E (EGIC)

Marking of Fittings

1. The Brand
2. Nominal size
3. The degree of the angel.
4. The Number of Cavities.
5. The month and Year of Production.
6. Material type (pvc-u)





Material and Technical Specifications

2.5. Raw Material

vPoly Vinyl Chloride (PVC)

Poly Vinyl Chloride is related to polyethylene, and is also produced by the polymerization of ethylene. The structural formula of Poly Vinyl Chloride differs from that of polyethylene in that on every second carbon atom of the chain molecule a hydrogen atom is replaced by a chlorine atom. These chlorine atoms may either be arranged on both sides of the carbon atom (atactic),

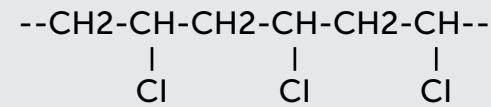

or all the groups can be on only one side (isotactic). Commercial polypropylenes are exclusively isotactic.

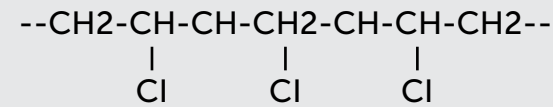

Its formula:

Poly Vinyl Chloride is polymerized by different methods; the most famous are suspension and emulsion.

Suspension poly Vinyl Chloride is used in Pipes and Fittings but must be mixed with some additives (heat stabilizer, lubricants, color, etc. ...).

Technical Specifications

Characteristic	Unit	Values
Physical Properties		
Density	kg/cm ³	1.38
Water Absorption	mg/cm ²	0.71
Mechanical Properties		
Modulus Of Elasticity	N/mm ²	3000
Compressive Strength	N/mm ²	66
Flexural Strength	N/mm ²	95
Tensile Strength	N/mm ²	50
Impact Strength (Charpy)		No Break
Shore Hardness	R	115
Mechanical Properties		
Vicat Softening Temperature	°C	>82
Max. Operating Temperature	°C	60
Longitudinal Reversion		< 2 %
Specific Heat	KJ/Kg.K	
Coefficient of Thermal Expansion	m/m.K	8 x 5 ⁻¹⁰
Thermal Conductivity	W/m.K	0.16
Electrical Properties		
Volume Resistivity	Ω.cm	>10 ¹⁴
Surface Resistance	Ω	2.4*10 ¹²
Dielectric Strength	Kv/mm	>40



System Design

2.6. Structural Design

Smart Home range of PVC pipes are classified as "flexible" pipes, which means they have the ability to deform or deflect diametrically within specified limits without structural damage or without impairing the performance of the pipes. The external soil and live loadings imposed on flexible pipes may cause a decrease in the vertical diameter and an increase in the horizontal diameter of the pipe. The horizontal movement of the pipe walls in the soil material at the sides develops a passive resistance within the soil to support the external load. Hence, the pipeline performance is influenced by the soil type and density. The higher the effective soil modulus at pipe depth, the less the pipe will deflect.

2.7. Important Design Principle

Pipe Sizes

The correct sized pipes should be used throughout the installation to ensure an efficient flow through the drainage system. (Gradient sizes)

Access

Access to a drainage system should be included wherever there is a change in direction.

Venting

All drainage systems require a vent to allow fresh air to be taken into the system to ensure a smooth running to the discharge.

Expansion

It is important to allow for expansion in all plastic drainage system. Solvent weld systems should use expansion joints where required.

Traps

Each appliance (Shower, Basin etc.) should have its own trap. Connection to a floor gully provides an additional trap to prevent foul odors from escaping into living space areas.

2.8. System Advantage

Smart Home systems offer integrated solutions. This enables and helps installers to assemble complete drainage, plumbing systems from a single source, with complete confidence in compatibility and performance. All systems are backed by comprehensive technical support and a nationwide distribution network to ensure availability when and where required.

Smart Home characterized by the following features:-

- High-quality product
- Excellent fluid flow characteristics
- Immunity to all types of corrosion
- Good mechanical strength
- High ring stiffness
- Fast and easy installation
- Lightweight, ease of installation, ease of maintenance
- Good electrical insulation properties



"Eco Friendly Connections"

INDEX

Quality Assurance

3.1. System Standards	78
3.2. System Control	79
3.3. Internal Control	79
3.4. Testing and accepting incoming Goods	81
3.5. In-process Inspection	81
3.6. Process Control	81
3.7. Final Inspection	81
3.8. External Control	83
3.9. Quality Management	83

Quality Assurance



3.1. System Standards

Smart Home manufacturing according to the following standards:

ES 733/2005

PLASTIC STANDARD ATMOSPHERES FOR CONDITIONING AND TESTING

F441

STANDARD SPECIFICATION FOR CPVC PLASTIC PIPE, SCHEDULES 40 AND 80

ASTM 1785

POLYVINYLE CHLORIDE (PVC) PLASTIC PIPE, SCHEDULES 40 , 80 and 120

IQS 1512/1989

UNPLASTICIZED POLYVINYL CHLORIDE FOR DRAINAGE INSIDE BUILDINGS

ES 1717/2008/

Pipe and Fittings made of Unplasticized Poly (Vinyle Chloride) (PVC-U) for underground drainage and sewage system

ES 848-1/2008/

Pipe and Fittings made of Unplasticized Poly (Vinyle Chloride) (PVC-U) for water supply system

DIN 8061/8062/

Unplasticized Poly (Vinyl Chloride) (PVC-U) Pipes

DIN EN-1401

Plastic piping system for non-pressure underground drainage and sewerage- Unplasticized Poly Vinyl Chloride (PVC-U)

DIN 19534

Plastic piping system for non-pressure underground drainage and sewerage- Unplasticized Poly Vinyl Chloride (PVC-U)

ISO 3633

Plastics piping systems for soil and waste discharge (low and high temperature) inside buildings -Unplasticized Poly (vinyl chloride) (PVC-U)

ASTM D 2665

Poly (Vinyl Chloride) (PVC) Plastic Drain, Waste, and Vent Pipe and Fittings

ASTM D 3311

Standard Specification for Drain, Waste, and Vent (DWV) Plastic Fittings

DIN EN 1329

Poly (Vinyl Chloride) (PVC) Plastic Piping System for soil and waste discharge (low and high temperature within the building structure

ISO 4435

Plastics piping systems for non-pressure underground drainage and sewerage – Unplasticized poly (vinyl chloride) (PVC-U)

ISO 9969

Determination of ring stiffness for Thermoplastics pipes

DIN 4102

Fire behavior of building materials and building components

3.2. System Control

The production of Smart Home superior high-quality piping system calls for the regulation and control of all areas of the operations. All results are documented and archived:

- Testing and accepting incoming goods
- Process Control
- In- process inspection
- Final inspection tests

Regulation for the quality control of Smart Home drainage system includes all above standards that feature the minimum requirements for internal control. Conformance to the superior quality standards is verified through independent authorities, by internal audits and Laboratory tests. Smart Home quality standards are controlled by Egypt's regulations.

EGIC is a highly qualified and experienced manufacturer in extrusion and injection molding. EGIC is also the market leader and pioneer in the manufacturing of PVC-U drainage system in Egypt. This is reflected in our internal quality standards and procedures, which are illustrated by the constant quality of our products.

3.3. Internal Control

A team of highly trained and qualified QC engineers, equipped with a state of art laboratory, ensures that all tests are carried out in compliance with our quality control policies, which include:

- Testing all Raw Materials.
 - Measuring and inspecting our production equipment.
 - Auditing our production procedures.
 - A final inspection of the quality of our finished products.
 - All internal quality audits are documented and archived in accordance with the highest standard quality control policies.
-

EGIC Laboratory

EGIC laboratory serves one of the most important functions in our production and process control. A significant portion of the EGIC regulations pertains to the quality control laboratory and product testing to be able to produce the highest quality products.

EGIC laboratory has the most advanced equipment made in Germany with high technology.

EGIC Laboratory Equipment:-

- Universal Testing Machine - Tensile Tester
- Hydrostatic Pressure Tester
- Shore Hardness Tester - Durometer
- Charpy / Izod Pendulum Impact Tester
- Gardner Impact Tester
- Falling Dart Impact Tester
- Full Notch Creep Tester
- Melt Flow Tester - Melt Flow Indexer - MFI
- Specific Gravity Tester - Densimeter
- Sample Specimen Preparation Equipment
- Milling Machine
- Thermo bath
- Thermo oven
- Laboratory Granulator
- Apparent / Bulk Density Tester
- Laboratory Mixer
- Laboratory Roll Mill
- Platen press
- VST/HDT tester
- Limiting Oxygen Index Chamber
- Brittleness Point Temperature Tester
- Moisture content apparatus
- Differential Scanning Calorimeter
- Sieve Analysis Tester
- Humidity Tester
- Viscometer Tester
- Drying time apparatus
- Bending resistance tester
- Rotary Microtome
- Pigment dispersion Tester
- Microscope Axio Imager
- Methylene chloride tester
- Weathering tester
- Sieve analysis tester
- Congored tester



3.4. Testing and Accepting Incoming Goods

All incoming goods are carefully inspected, to ensure that the raw material conforms to the set requirements. Goods that haven't been tested don't release for production. The incoming raw materials are tested according to SO 2859, ES 1991, EGIC standard and data sheet.

3.5. In-Process Inspection

The quality plan requires that all inspections are carried out at the beginning as well as during production. As production starts, all relevant data are checked by the quality assurance department.

Pre-production samples are tested by the laboratory engineers and technicians for the following tests:-

- Surface finish
- Dimensional accuracy
- Check Marking
- Date for extrusion and injection molding machines
- The product is only released if optimal tests are achieved

3.6. Process Control

We have an extensive quality control process in the field of extrusion, which uses Ultrasonic measurements and data recording. This enables constant observation and control of production. Ultrasonic measurements automatically track and report any deviations intolerance of the cutting device on the extrusion machine, thus isolating any substandard products. This ensures that only perfect quality products are packed and stored. All data received during production is studied and analyzed in details.

3.7. Final Inspection

QC requires that inspections and tests are carried out on all finished products. The results are all documented. Finished products are only released to storage when all tests and inspections have conformed to authorized procedures and specifications. The final tests include a time-lapse procedure. This measures the usability of the products in their fields of application, as well as removing production weaknesses. These inspections are the method for quality assurance during production and for design tests. The results document the system quality and services to optimize the manufacturing process.

The final inspection covers the following main tests:-

Visual control

Aspect, roughness, opacity, conformity of color, chamfer, porosity, detecting any trace of burning, clean-cut control, no irregularities, ... all those controls are performed without magnification, they allow to detect any eventual trouble in the manufacturing process at the closest points of the extrusion lines.

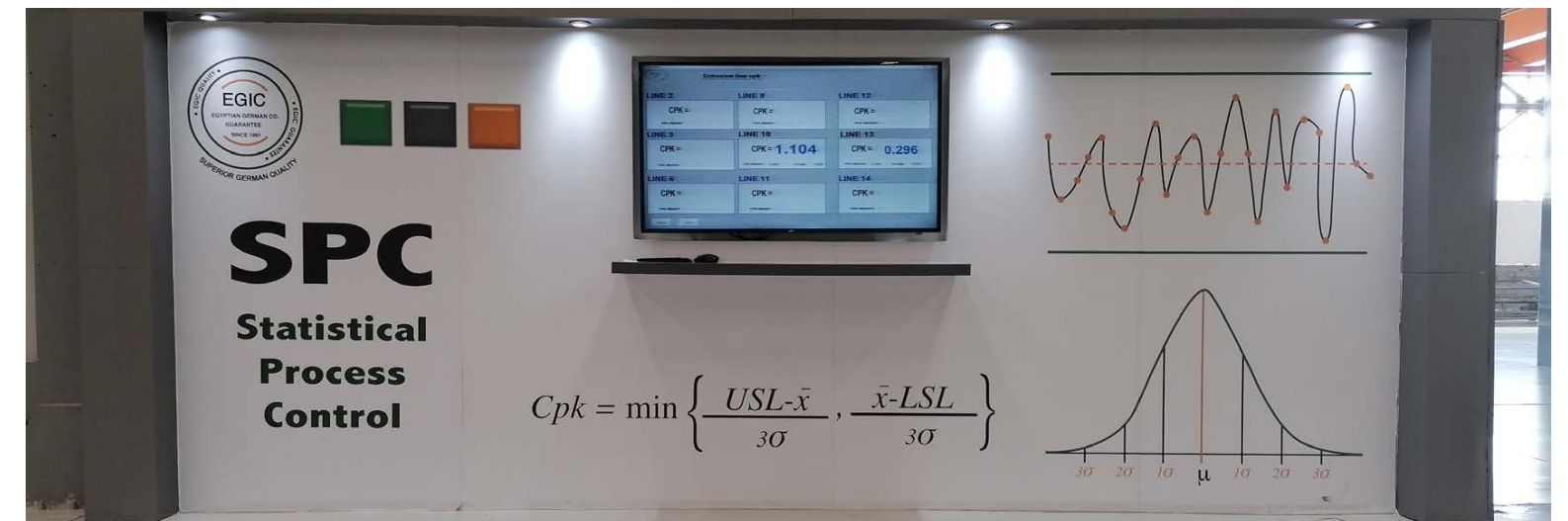

Dimensional control

Outside diameter, wall thickness (8 points), overall length, (length, groove, etc...), out of roundness, and mean outside diameter, measured with the adequate calibrated measuring instruments. This test is carried out according to the ES 1717 standard and ISO 4435.

Impact resistance:

A calibrated weight from a specified height falls on the product a number of times, without any friction: passing the test demonstrates the impact resistance of the PVC product according to ES 1717 and EN 744 standard.

Methylene Chloride

Product is tested by immersion in methylene chloride, a very corrosive solvent, at 23°C for 20 minutes. The tested product should show no attack at any point of the pipe (internal, external, through the wall), proving that the fusion temperature has been reached. If this point is not reached, the filler used in the formulation for lubrication flows between the molecules to the surface and proves that the polymerization is not complete, and thus: the properties of PVC are not met. This ageing test reveals the imperfection of the product. A product is in compliance if the mix of temperature-pressure-speed is well tuned in order to reach the fusion point (very variable according to the product, conditions, material, ...) but still not reaching the degradation stage (burning); because the measurement of the degree of fusion is very costly and almost impossible to obtain with the number of variables, the solvent test is a substitution considered as very accurate. This test carried out according to the ES 1717 standard.

Longitudinal reversion:

A sample of the product is immersed in an oven for 30 minutes at 150 °C: all tensions released at this temperature are considered as the beginning of fusion. The product is then cooled at ambient temperature, and the deformation is measured (shrinkage is acceptable if smaller than 5%). This test helps to identify some processing abnormalities that might affect the pipe dimensions at long term, by evaluating the effect of heating on the pipe. This test is carried out according to EN 743 standard.

Vicat softening point

A sample is immersed in oil and the temperature is elevated from ambient one until it reaches its softening point (the minimum acceptable temperature is 79°C). The softening point is reached when a calibrated needle under a weight of 5kg penetrates up to 1mm into the product. Higher point demonstrates the ability of the pipe to withstand high temperature. This test is carried out according to EN 727 standard.

Specific gravity

It allows verifying that the PVC content complies with the requirements of the DIN 1401 standard (at least 80% by mass for pipe, and more than 85% for fittings), failing which the pipe will not withstand long-term operation (50 years). This test allows demonstrating that the filler content does not exceed a reasonable percentage of the mixture.

Internal Pressure

Internal pressure resistance test for pipe and fittings carried out according to ES 1717 and EN 921. Pipes and fittings didn't burst or leak during the stressing period. Time and temperature values must be as in standards.

Marking

Marking should be in compliance with the requirements of ES 1717 standard as well as those of the brand. It should include all useful data allowing the traceability of the manufacturing process and all the steps of the quality control.

3.8. External Control

External supervision consists of measuring the fixed scope at fixed intervals. The respective supervising institutions appoint the appropriate authorized organization to carry out external supervision. Inspection includes:

- External tests of products
- Internal audit of Smart Home quality assurance system and test procedures
- Calibration of test equipment
- Hygienic and toxicity tests

3.9. Quality management

Smart Home is developed and manufactured within an ISO 9001 Quality assurance system. It emphasizes quality care and continuous improvements for customer satisfaction.

Furthermore, Smart Home has integrated the ISO 14001 environmental management system to control and improve our overall environmental performance.

Smart Home also integrated OHSAS 18001, Occupational Health and Safety Management systems.





INDEX

Installation

4.1	Introduction	86
4.2	Procedure	87
4.3	Installing of pipe clamps	88
4.4	Trenchin	90
4.5	Pipe assembly	95

4.1. Introduction

One of the most significant advantages of Smart Home PVC-U pipe system is its light weight. This means that the pipe can be easily handled and longer lengths can be installed without sophisticated lifting machinery and with minimum in-trench labor.

Long pipe lengths increase the speed with which a system can be installed and also mean that pipelines are less susceptible to misalignment and consequent blockage following possible ground movement than those made up of short pipe lengths.

All pipework must be supported whether vertical or horizontal.

Pipe brackets must be used to anchor expansion joints. Intermediate support must also be provided to steady pipework between points.

Horizontal pipework requires more frequent support than vertical pipework.

Pipework should always be supported close to any change of directions (e.g. Bends or branches).

4.2. Procedure:

1. Cutting:

Pipe cut must be upright for proper jointing with fitting socket.

2. deburring:

Use a file to remove burrs from the pipe.

3. Cleaning:

Wipe end of pipe and inside of fitting with clean cloth to remove dirt, grease and/or moisture. Do not apply adhesive until pipe is clean and dry.

4. Check and mark:

Be sure the pipe and/or fittings are evenly cut. Measure the length of the fitting's socket depth and then mark the length on the pipe.

5. Assembling:

Apply a thin coat of the adhesive outside the pipe and inside the fitting. While the adhesive is still soft, insert pipe softly into the fitting with a 1/4 circle twist. Hold them firmly together 15 to 30 seconds (hold longer for larger pipes).



4.3. Installing of pipe clamps

Smart Home wastewater piping systems are always to be laid so that they are free of tension, and changes in length are not inhibited.

Generally, pipe clamps with inserting tapes are to be used for fixing the pipes. These tapes have to be adjusted to fit the outer diameter of the pipe and must fully surround the pipe. No insertion tape should be used; the interior edges of the clamps must be rounded and the inner surfaces must be smooth.

Fixed clamps

By fully tightening the pipe clamps, fixed points (fixed clamps) are created in the piping system.

They are therefore to be arranged in such a manner that any slipping of a pipe is prevented. In the case of a pipe with a socket, the fixed clamp is to be installed directly behind the socket.

Fittings and groups of fittings are to be fixed points at all times.

Loose clamps

Not completely tightened pipe clamps (loose clamps), when installed, must also allow for a lengthways movement of the piping. Therefore, the inner diameter of the clamp must be slightly greater than the outer diameter of the pipe after installation.

Spacing pipe clamps

For recommended pipe clamp spacing, see the table below:

Nominal outer Diameter (mm)	Piping	
	Horizontal(m)	Vertical(m)
32	0.5	1.2
40	0.5	1.2
50	0.5	1.2
75	0.8	2
90	0.9	2
110	1.1	2
125	1.25	2
160	1.6	2

Laying piping in walls

The gaps in the walls are to be constructed in such a manner that tension-free installation is possible.

Insofar as the pipes are directly covered in plaster, i.e. without using a plaster support or a covering, one must make sure that the pipes are rounded by ductile materials such as corrugated paper or board, mineral wool or glass wool.

Respective measures must be taken (insulating the heat-conducting pipes, for example, heating pipes) at points at which higher temperatures may occur as a result of external influences.

Horizontally-laid pipes (connecting pipes or collecting connecting pipes) which, for example, serve as a connection for several installation elements for installation outside walls, should be lined over their entire length. In doing so, the extension of the length of pipes and fittings is not to be inhibited.

Special application

The systems are more than adequate for normal domestic applications in low and high rise buildings. Where more specialized applications, such as hospitals, industrial kitchens, and laboratories are concerned, where prolonged discharges of liquids at elevated temperatures can occur.

Use of short lengths of pipe

PVC-U pipe may be cut on site when shorter lengths are required to suit the installation, or for the installation of fittings.

The cutting of PVC-U pipe is easily achieved using a fine-toothed handsaw or a PVC-U pipe cutter. The position of the cut should be measured and carefully re-checked before cutting: reasonable accuracy should be exercised to ensure that the cut is square to the axis of the pipe and all burrs must be removed from the cut end before making a joint.

4.4. Trenching

There are a lot of important notes that must be taken into consideration for underground installation of PVC drainage pipe in trench construction:-

- Excavation should comply with all applicable laws and regulations.
- Excavated material such as debris and removed pavement is not suitable for trench backfill.
- Where dewatering is necessary, water should be removed until the pipe has been installed and the backfill has been placed to a sufficient height to prevent flotation of the pipeline.
- The maximum earth load on the flexible pipe is the weight of the material directly over the pipe (prism load). Unlike the rigid pipe, the width of the excavated trench does not affect pipe loading. Trench width is based solely on practical and economical construction.

See Figure 3.1 for trench terminology

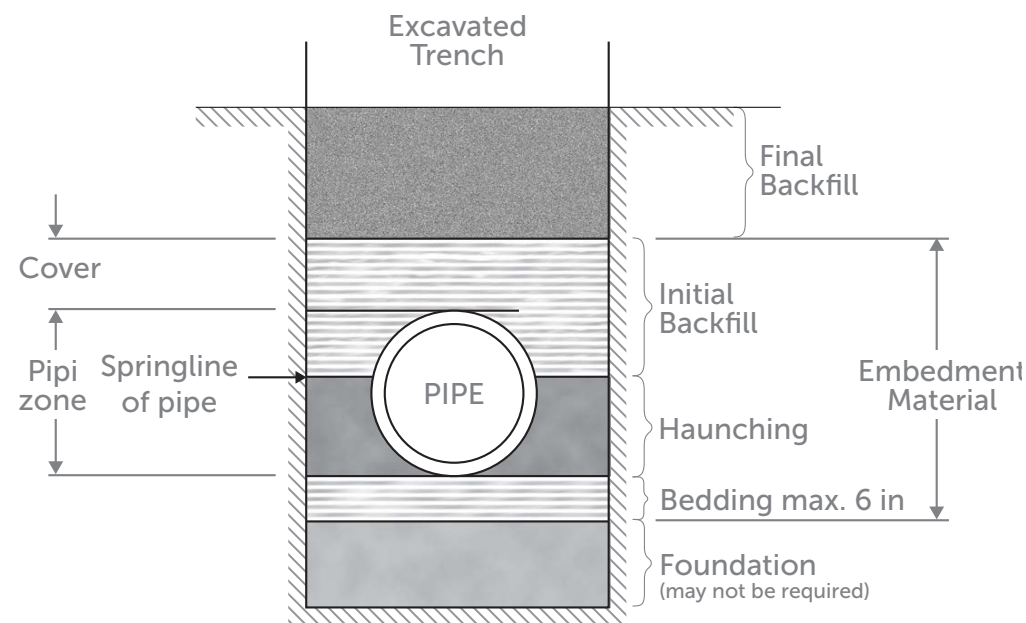

Foundation:

A foundation is necessary only when native soils are unstable. For such conditions, the trench is over-excavated and a layer of supportive material is placed and compacted to provide a firm foundation for the subsequent pipe embedment materials.

Embedment:

This zone is the most important in terms of pipe performance. It is divided into the following subzones:

Bedding:

Typically, four to six inches of supportive, compacted material. This zone provides even support for the pipe and brings it to grade.

Haunching:

It extends from the bottom of the pipe to the centerline of the pipe (spring line). It provides the most resistance to pipe deflection. Specifying proper materials and compaction are most important for this zone.

Initial Backfill:

It extends from the spring line to a point above the top of the pipe. This zone provides some pipe support and helps to prevent damage to the pipe during placement of the final backfill. The cover extends from the top of the pipe to the top of the initial backfill. The depth of cover should be as much as necessary to protect the pipe during the placement of the final backfill. Twelve inches is a common depth of cover.

Final Backfill:

This zone extends from the top of the initial backfill to the top of the trench. This zone has little influence on pipe performance but can be important to the integrity of roads and structures.

Installation Trenches:

Trenches should be excavated in accordance with plans and specifications. They should be as narrow as practicable at the level of the top of the pipe and, in a straight trench, have a bed width not less than 200mm wider than the pipe diameter or three-time pipe diameter, to provide working space for the laying crew.

Trenches, when excavated, are either 'stable' or 'unstable'. The category into which a trench fit is affected by the soil conditions, width, depth, and method of excavation. To ensure that maximum support is given to the buried pipe by the undisturbed ground, the resultant stable or unstable trench should be treated.

Stable conditions:

Stable conditions are those where, after excavation, the trench walls remain solid and do not show any signs of collapse or cave in. Under such conditions the recommended trench widths are shown in the following table:

Pipe Diameter (mm)	Normal Width (mm)
110	400
160	600
250	750

Unstable conditions:

Unstable conditions are those where, during or after excavation, the trench walls tend to collapse and cave in. Under these conditions, in open or unrestricted areas, the top of the trench can be widened until stability is reached. A smaller trench should then be dug in the bottom of the excavation to contain the pipe as shown. In areas where space is limited, e.g. in streets, it may be necessary to support trench walls by timber or other suitable shoring.

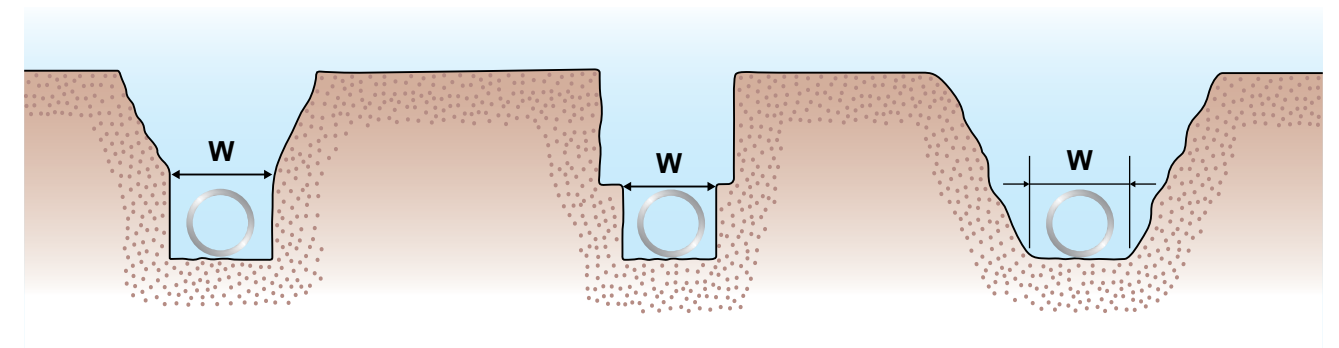
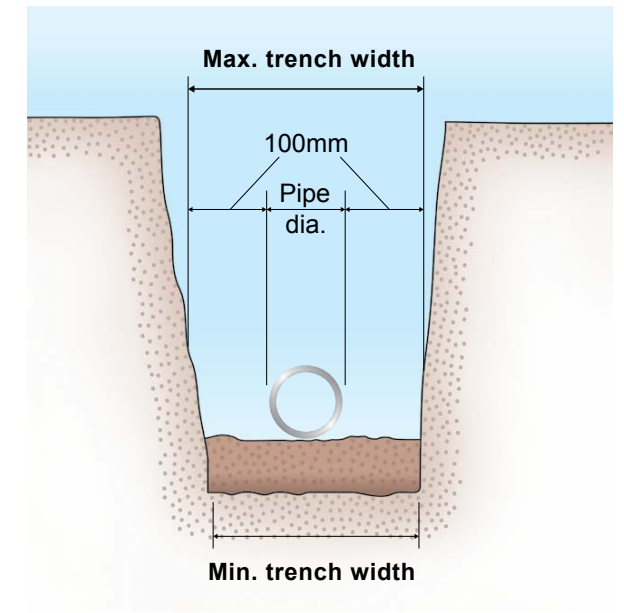

Trench depths:

The minimum trench depth should be such that pressures created by the weight of fill material, plus anticipated traffic or other superimposed loads, will not damage the pipes. As a guide, the recommended minimum clear cover above is listed below:

Condition	Min Cover Depth
Where no subject to vehicular loading	300 mm
Where subject to vehicular loading Under driveways	450 mm
In sealed roadways	600 mm
In unsealed roadways	750 mm

Laying and Compaction

Preparing the trench

The trench bottom should be as level as possible so that the barrel of the pipe is fully supported along its whole length. In good working conditions, sandy or loamy soil, the trench bottom can be made sufficiently even with stones and rocks removed to provide continuous support for the pipes without the need for under-bedding.

Wet conditions

In the wet ground, sloppy working conditions can be alleviated by first placing a layer of hard granular material, or by dewatering the area in and around the trench. If patches of ground are so wet that there is a risk of subsidence and possible damage to sections of the pipeline, these areas should be consolidated by the addition of suitable fill material.

Trench installation:

The trench should be excavated deeply enough to allow for the specified grade, the required depth of bedding, and the minimum cover over the pipe. The figure below suggests the following typical installation in a trench.

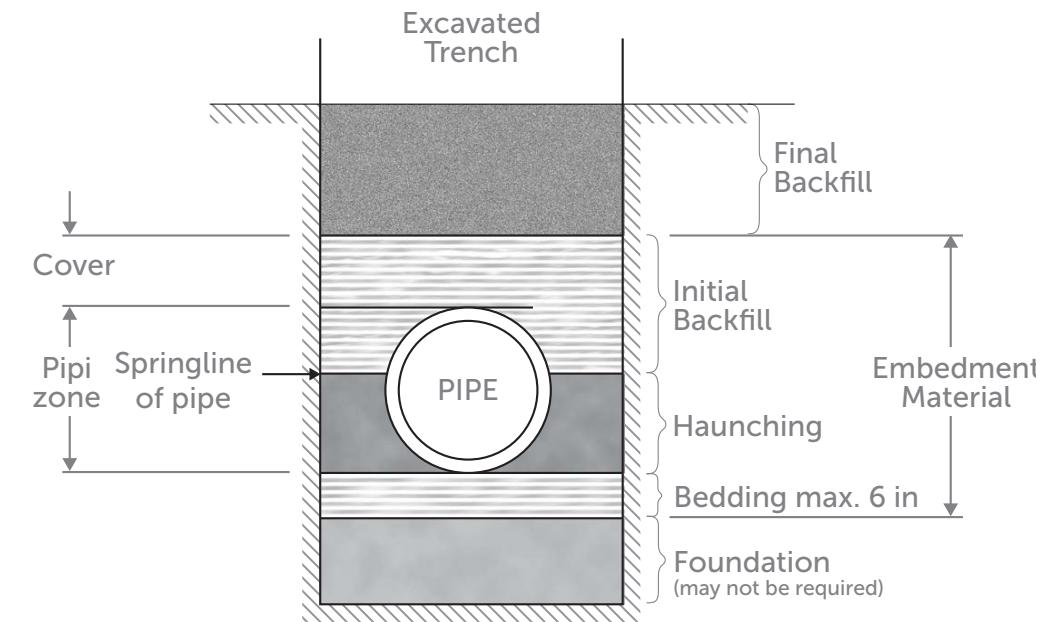

The following materials are suitable for bedding and overlay in the trench:

- Suitable sand, which is free from rock or other hard or sharp objects.
- Crushed rock or gravel of approved grading up to a maximum size of 14mm
- The excavated material, if it is free from rock or hard matter and broken up so that it contains no soil lumps, having any dimensions greater than 75mm which would prevent adequate compaction of the bedding.
- Cement mortar, containing one part of cement and four parts of sand by volume, mixed with clean water to a workable consistency (bedding only).

Completing site work:

Once the pipe is laid in the trench, backfilling can commence. Two distinct phases are involved with pipelines:

- Backfilling prior to testing the pipeline
- Backfilling after testing the pipeline

Backfilling usually follows pipe installation as closely as possible in order to protect the pipe from external damage, to eliminate the possibility of the pipe floating due to flooding of open trenches, and to avoid shifting the pipe out of line due to cave-in.

It should be remembered that the purpose of backfilling is not only to protect the pipe by covering it but to provide firm continuous support under the pipe. Where concrete or mortar bedding has been used, however, the bedding must have obtained its required strength prior to backfilling.

Initial Backfilling:

The first step in providing firm continuous support for the pipeline is to tamp soil solidly under the entire barrel of the pipe, and to take care of not disturbing the grade.

This backfilling material should be free from stones, rock or clay. When this is not available, other suitable material e.g. loamy earth or sand should be taken to the site. The initial backfilling should be placed by hand shovel in layers not exceeding 300mm in deep. Each layer should be well-tamped round and under the pipeline using the long tamper illustrated. In this way, air pockets are eliminated from beneath the pipe.

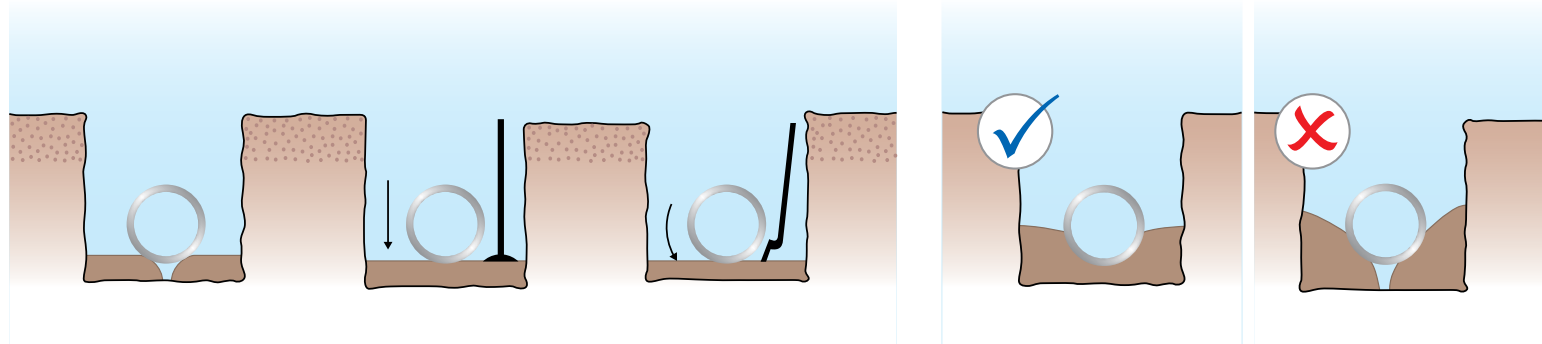

The first step in providing firm continuous support for the pipeline is to tamp soil solidly under the entire barrel of the pipe, and to take care of not disturbing the grade.

This backfilling material should be free from stones, rock or clay. When this is not available, other suitable material e.g. loamy earth or sand should be taken to the site. The initial backfilling should be placed by hand shovel in layers not exceeding 300mm in deep. Each layer should be well-tamped round and under the pipeline using the long tamper illustrated. In this way, air pockets are eliminated from beneath the pipe.

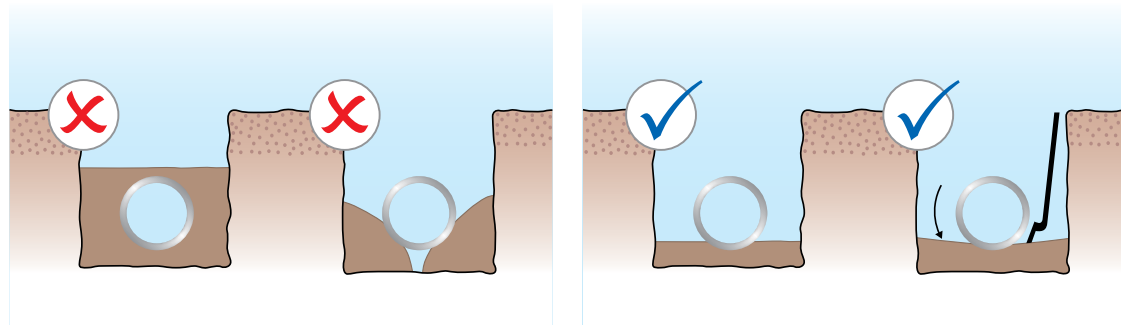

Pipe joints should be temporarily left exposed when placing the initial backfill to enable pressure tests to be carried out. After testing the line, backfilling and final filling may be completed.

Testing and Inspection:

Once the roughing-in is completed on a Smart Home system, it is important to test and inspect all piping for leaks. Concealed work should remain uncovered until the required tests are made and approved. When testing, the system should be properly restrained at all bends, changes of direction, and the end of runs. There are various types of procedures used for testing installed plastic systems. However, a water or hydrostatic test is a technically superior test method for inspecting completed PVC-U piping system installation and is the testing procedure recommended by plumbing code standards. The purpose of the test is to locate any leaks at the joints and correct them prior to putting the system into operation. Since it is important to be able to visually inspect the joints, a water test should be conducted prior to closing the piping or backfilling of underground piping.

Water Test

The system should be properly restrained at all bends, changes of direction, and the end of runs. To isolate each floor or section being tested, test plugs are inserted through test tees in the stack. All other openings should be plugged or capped with test plugs or test caps. Fill the system to be tested with water at the highest point. As water fills a vertical pipe, it creates hydrostatic pressure. The pressure increases as the height of the water in the vertical pipe increases. Filling the system slowly should allow any air in the system to escape as the water rises in the vertical pipe. All entrapped air in the system should be expelled prior to the beginning of the test. Failure to remove entrapped air may give faulty test results.

Once the stack is filled with a visual inspection of the section being tested, it should be made to check for leaks. If a leak is found, the joint must be cut out and a new section must be installed. Once the system has been successfully tested, it should be drained and the next section should be prepared for testing.

Completing Final Backfill:

After testing the pipeline, selected material should be hand shoveled over each exposed joint and tamped to give 300mm minimum cover. Final backfilling to ground level can be completed by hand or machine, using the soil originally excavated from the trench. Care should be taken to exclude large rocks and stones from the final backfilling.

4.5. Pipe assembly**Basic Principles of Solvent Cement Welding**

- The joint surfaces must be softened and remain wet with solvent cement during joint assembly.
- Sufficient solvent cement must be applied to fill the gap between the pipe and fittings.
- Assembly must be made while the surfaces are still wet and the solvent cement is still fluid.
- Joint strength develops as the solvents evaporate from the joint.
- Cleaner primer must be used to prime and clean all jointing surfaces, prior to the application of solvent cement. No exceptions. Cleaner primer softens the surface and is essential to a successful jointing process.
- Do not prepare the surface using sandpaper as contamination can occur.
- No additive of any kind should be introduced to the cleaner primer, or to the solvent cement. Ensure that the solvent cement is in good condition and runs freely from the brush.
- If the cement does not run freely or appears "globular" or "tacky", discard and use a fresh stock of solvent cement.
- Ensure that the cement is within its recommended "use by" date.
- In cold weather conditions, solvents penetrate and soften the PVC surfaces much slower. Therefore, it is more important to pre-soften the jointing surfaces with a cleaner primer. Because of slower evaporation of the solvents, a longer cure time will be necessary.
- We recommend the use of disposable polyethylene gloves when applying cleaner primer and solvent cement fluids.
- Solvent cement and cleaner primer are highly inflammable liquids and should be kept away from all sources of ignition, they may be harmful if swallowed or inhaled and may cause skin or eye irritation. Avoid breathing the vapor, use in well-ventilated areas.

Storage, Handling and Transportation



INDEX

Storage

5.1	Introduction	100
5.2	Procedure	101

5.1. Storage

The following recommendations relate to the storage of Smart Home PVC-U pipes under the normal climatic conditions.

- Pipes should be uniformly supported throughout their length, if this is not possible timber battens at least 75mm wide at spacing not greater than 1m centers should be placed beneath the pipes. Preferably pipes of different sizes and wall thicknesses should be stacked separately. Where this is not possible, the pipes with larger diameters and thicker walls should be at the bottom. It is preferable that pipes should not be stacked one inside the other.
- Pipe stacks should not exceed 7 layers with a maximum height of 1m.
- Ideally, stacks should contain one diameter pipe size only. Where this is not possible, stack largest diameter pipes at the base of the stack. Small pipes may be nested inside larger pipes.
- If stored in the open for long periods, or exposed to strong sunlight, cover the stack with opaque sheeting.
- Store fittings undercover. Do not remove from cartons or packaging until required.
- Store solvent cement and cleaning fluid in a cool place.
- Ultra-violet light can affect pipes and fittings: pipe color may change

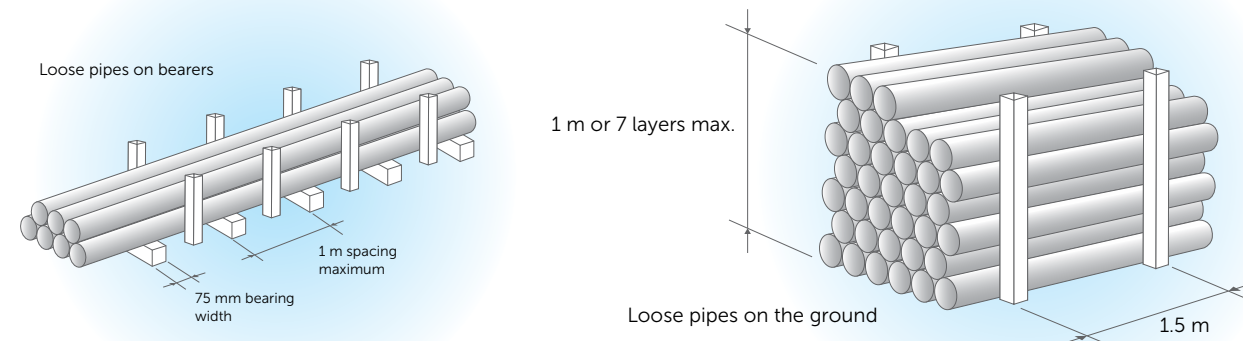

5.2. Handling

Although pipes made from PVC-U are strong, they are light in weight so they can be very easily handled. However, it is necessary to take care to prevent damage; in particular, pipes should not be thrown, dropped or dragged along. If pipes are moved by rolling, it is necessary to support them along their length and properly restrain them on inclines.

If pipes are loaded or unloaded by mechanical means (forklift, crane etc.), care should be taken to prevent damage. Pipes should be properly supported in two places when lifted. Preferably protected slings should be used; if metal chains and hooks are all that is available, padding should be placed between them and the pipes. If pipes are delivered stuffed, special care should be taken to avoid damage during unloading.

- Take all reasonable care when handling PVC, particularly in very cold conditions when the impact strength of the material is reduced.
- Do not throw, drop, or drag pipes along hard surfaces.
- In the case of mechanical handling, use protective slings and padded supports.

Metal chains and hooks should not make direct contact with the pipe

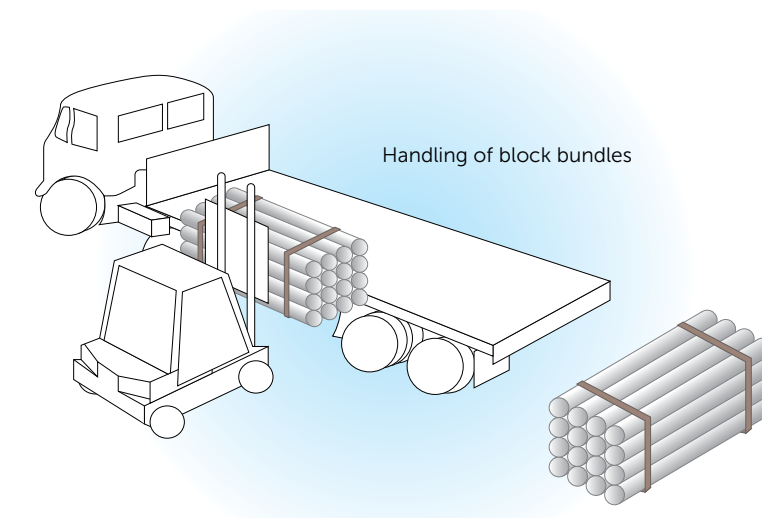

5.3. Transportation

- Vehicles with a flatbed should be used for the transport of pipes. The bed should be free from nails or other projections. Each pipe should be supported uniformly along its length. Vehicles holds have adequate side supports at not more than 1.5m centers and pipes should be well secured during transit. All uprights should be flat and free from sharp edges.
- Pipes should be loaded onto vehicles in such a way that any overhang does not exceed 1m.
- Thick walled pipes must be loaded before thin walled pipes.



Zero Leakage, Zero Contamination, Zero Corrosion, Zero Blockage

Ver.1



www.egic.com.eg

Address: industrial Zone no. 4, 6th of October
city, Egypt
industrial Zone no. 2, Bani Sweif, Egypt

info@egic.com.eg / export@egic.com.eg
customer service: 19678